

THE COMPANY

TURCK is one of the leading manufacturers in industrial automation and was one of the first companies to recognize the possibilities of automating production processes using electronic components. Specialising initially in the production of sensors, today we offer solutions for the ever more complex field of automation, ranging from sensors for the periphery, through various switching and interface devices to system technology. Moreover, TURCK develops and manufactures customised hybrid switching circuits and SMD assemblies.

This makes TURCK your first choice for all these products.

TURCK products not only fulfill national standards (DIN) but also European (EN) and international standards (IEC) and are manufactured according to DIN ISO 9001. For the European market, there are three production sites in Germany and one in Switzerland. In order to meet the special requirements of our North American customers, the products for this market are manufactured in the United States. This is just one of the reasons why TURCK has achieved the leading position in the inductive sensor market in the United States.

We focus on offering individual customer support and made-to-measure solutions. The basis of our success is the close cooperation



The **sensor range** comprises more than 1500 standard sensors; the **interface line** features 600 different devices for hazardous area and standard applications. Moreover, our **fieldbus programme** includes a large variety of fieldbus components with protection degree IP67 for the most frequently used fieldbus systems.

with our customers, using the most advanced production technologies and a worldwide distribution network. With more than 1,600 employees in 15 countries and representatives in over 60 countries, TURCK ensures competent support and solutions directly for the field and on the spot.

Your satisfaction is our success!

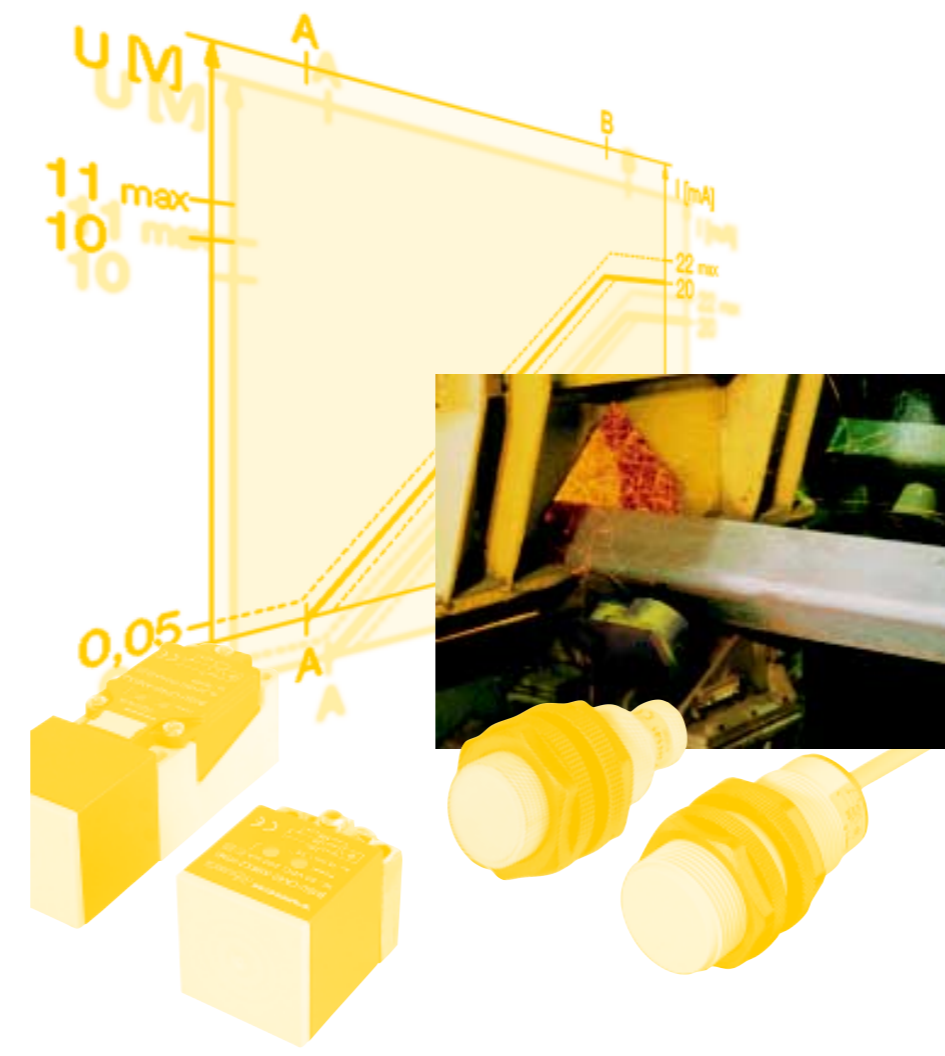

TURCK

INDUKCYJNE CZUJNIKI ANALOGOWE

Bitte senden Sie mir Unterlagen:

Sensortechnik

- Induktive Sensoren
- Induktive Sensoren für Schwenkantriebe
- uprox*® induktive Sensoren
- Kapazitive Sensoren
- Magnetfeldsensoren
- Opto-Sensoren
- Geräte für den Personenschutz
- Ultraschall-Sensoren
- Strömungswächter
- Druckwächter
- Temperaturwächter
- Steckverbinder
- CD-ROM Sensortechnik

Interfacetechnik

- Interfacetechnik im Aufbaugehäuse
 - Bauform *multimodul*
 - Bauform *multisafe*®
- Allgemeine Informationen
- Interfacetechnik auf 19"-Karte
 - Bauform *multicart*®
- Miniaturrelais, Industrirelais, Zeitwürfel, Sockel
- Zeit- und Überwachungsrelais
- Ex-Schutz - Grundlagen für die Praxis (Übersichtsposter)
- CD-ROM Interfacetechnik

Feldbustechnik

- busstop*®-Feldbuskomponenten
- Bussystem *sensoplex*®2
- Bussystem *sensoplex*®2Ex
- Bussystem *sensoplex*®MC
- Bussystem AS-Interface®
- Bussystem DeviceNet™
- Ethernet Netzwerkkomponenten
- BL20 I/O-Busklemmsystem
- Bussystem FOUNDATION™ fieldbus
- Bussystem PROFIBUS-DP
- Bussystem PROFIBUS-PA
- Bussystem *piconet*®
- Bussystem *excom*®
-

Please send me more information:

Sensors

- inductive sensors
- inductive sensors for rotary actuators
- uprox*® inductive sensors
- capacitive sensors
- magnetic-field sensors
- photoelectric sensors
- machine safety equipment
- ultrasonic sensors
- flow controls
- pressure controls
- temperature controls
- connectors
- CD-ROM Sensors

Interface technology

- devices in modular housings
 - *multimodul* style
 - *multisafe*® style
- general information
- devices on 19" card
 - *multicart*® style
- miniature relays, industrial relays, time cubes, sockets
- programmable relays and timers
- explosion protection - basics for practical application (overview poster)
- CD-ROM Interface technology

Fieldbus technology

- busstop*® fieldbus components
- bus system *sensoplex*®2
- bus system *sensoplex*®2Ex
- bus system *sensoplex*®MC
- bus system AS-Interface®
- bus system DeviceNet™
- Ethernet network components
- BL20 I/O bus terminal system
- bus system FOUNDATION™ fieldbus
- bus system PROFIBUS-DP
- bus system PROFIBUS-PA
- bus system *piconet*®
- bus system *excom*®
-

FAX-ANTWORT/FAX ODPOWIEDZ

Absender/Sender: _____

Name: _____

Firma/Company: _____

Abt./Position: _____

Adresse/Address: _____

Tel./Phone: _____ Fax: _____

E-Mail: _____

Internet www.turck.pl



D101302 0202

analog+: SIMPLY THE BEST FOR YOUR APPLICATION:

Analog sensors

Inductive sensors with analog output for simple measuring and control tasks provide a current or voltage signal which is proportional to the target's distance. TURCK's analog sensors provide a linear output signal relative to the distance between the target and the sensor's active face over the entire measuring range.

When monitoring **winding/unwinding procedures**, the analog sensor measures the roller's thickness and converts this value directly into a proportional current or voltage signal.



Workpieces of **different size or of various materials** and different types of tools will produce different output signals due to their diverse damping characteristics. Thus it is possible to distinguish between different kind of materials, for example various sorts of metal sheets.



Analog sensors made by TURCK provide optimum performance in all respects. They have outstanding properties such as:

- high accuracy
- large measuring ranges
- current and voltage outputs
- large variety of housings
- excellent EMC protection
- short-circuit and reverse-polarity protection
- all connection types

All these features ensure convenient handling and simple application, quite similar to a digital sensor!

VARIOUS HOUSING STYLES, FUNCTIONS AND MATERIALS – MADE-TO-MEASURE SOLUTIONS

The known and proven TURCK line of analog sensors has grown with the addition of new types, series **analog+**. The measuring range of these sensors has once again been extended, so that they are particularly useful in applications where large distances have to be detected and expressed by analogue signals.

However, if the application requires detection of minimal motion or deviation, the standard range of analog sensors is even more suitable. Their linearity and accuracy is even better due to the lower upper range value.

They can be used in the following applications:

Direct actuation

The highest accuracy is achieved if the sensor is directly actuated by the target. Both side and front actuation is possible. In order to utilise the full measuring range, it is important to work with an appropriately sized target. This may also be a moving part of the machine.

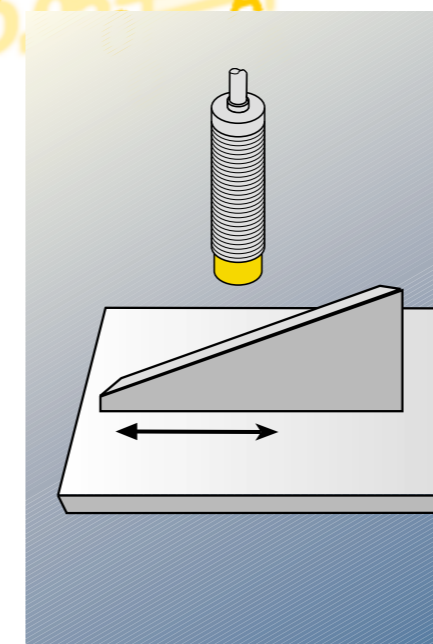
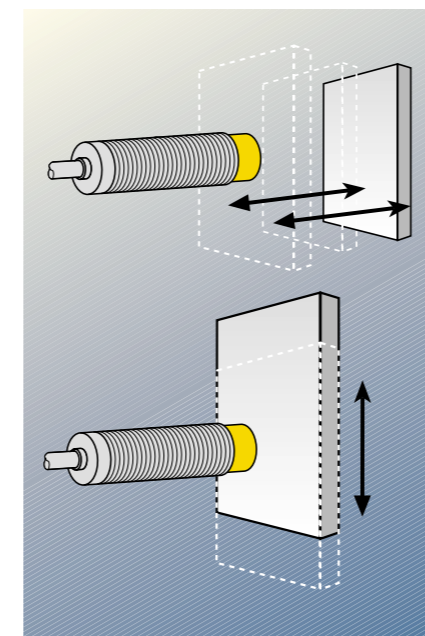

Actuation by a worm drive

A rotary movement can be performed by a worm drive. Every angular position of the axis can thus be assigned to a measuring value of the sensor. This is also an ideal sensing solution for incomplete rotary motion (e.g. positioning plates or swivel arms) where merely small angles have to be detected.

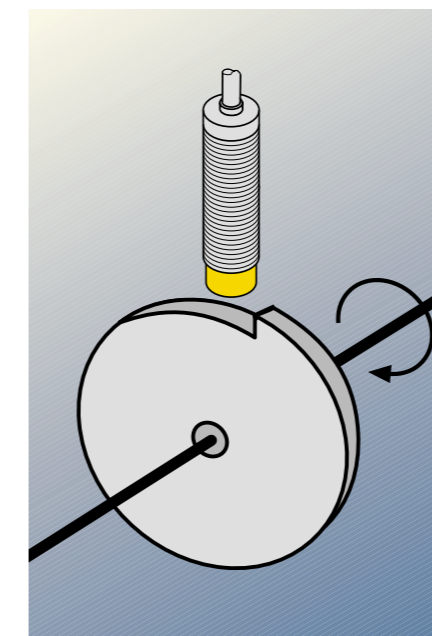

Actuation over an oblique plane

When detecting extensive linear motion and converting it into analog signals, the large distance across an oblique plane has to be reproducible by the measuring range of the sensor. Consequently, the sensor's resolution is spread over the long distance, but generally this creates no problems.

General data

- Supply voltage U_B 15...30 VDC
- Voltage output 0...10 V
- Load resistance $\geq 4.1 \text{ k}\Omega$
- Current output 0...20 mA
- Load resistance $\leq 400 \Omega$
- Repeat accuracy $\leq 1 \%$
- Temperature drift $\leq 0.06 \%/^\circ\text{C}$
- Temperature range -10...+70 °C
- Measuring range A...B

Protective circuits

- Short-circuit protection
- Reverse polarity protection
- Wire-break protection

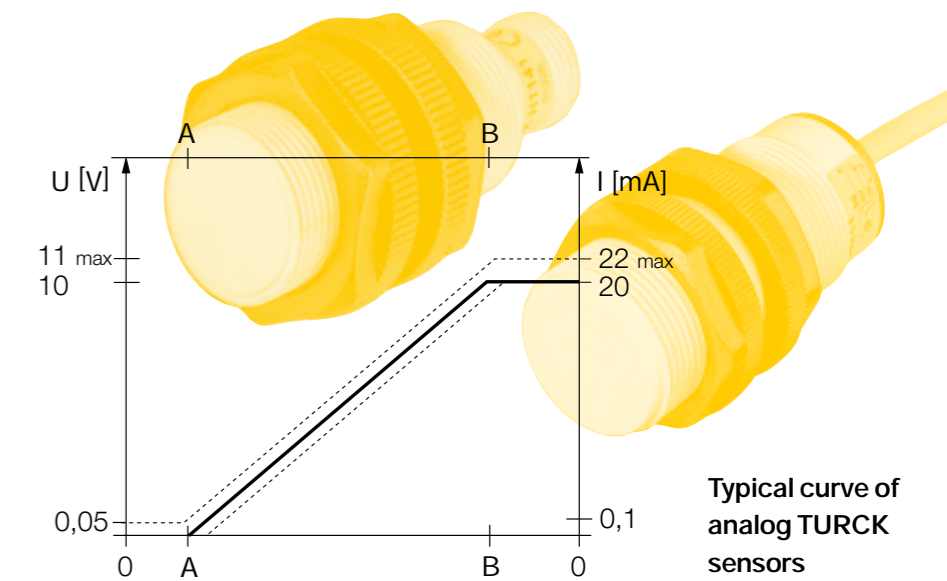

Threaded barrel sensors

Sensor type	Linear measuring range			
	standard		analog+	
	flush	non-flush	flush	non-flush
Threaded barrel				
M12	1.5 mm	3.5 mm	2.5 mm	–
M18 x 1	2.0 mm	4.0 mm	4.0 mm	6.0 m
M30 x 1,5	5.0 mm	10.0 mm	8.0 mm	–
Connection	cable or connector, M12 x 1			

Sensor type	Linear measuring range			
	standard		analog+	
	flush	non-flush	flush	non-flush
Rectangular, compact				
Q14 30 x 30 mm	5.0 mm	–	–	–
Q20 40 x 40 mm	7.0 mm	–	–	–
Q80 80 x 80 mm	–	–	–	40 mm
Connection	cable or connector, M12 x 1/M8			



Rectangular sensors - compact

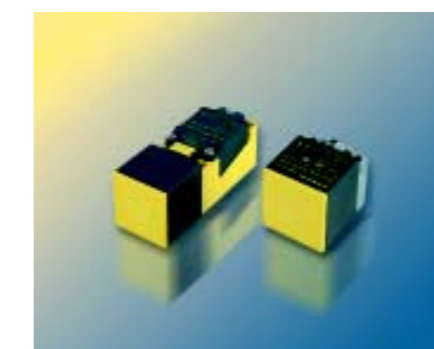

Rectangular sensors - variable

Sensor type	Linear measuring range			
	standard		analog+	
	flush	non-flush	flush	non-flush
Rectangular, variable				
CP40 40 x 40 mm	7.0 mm	20 mm	–	–
CK40 40 x 40 mm	7.0 mm	20 mm	–	–
Connection	terminal chamber (CP40), connector (CK40)			

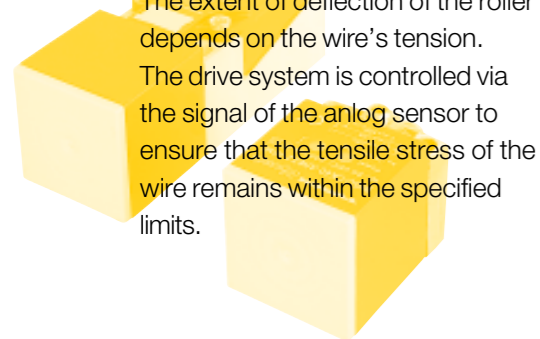

That's exactly why TURCK's analog sensors are used in many applications requiring more than simple digital positioning control.

In **tensile stress control applications**, in which wire tension is to be monitored, a wire is lead over an elastically supported roller which attenuates the analog sensor. The extent of deflection of the roller depends on the wire's tension. The drive system is controlled via the signal of the analog sensor to ensure that the tensile stress of the wire remains within the specified limits.

