

TURCK

AS-Interface®
FIELDBUS
COMPONENTS

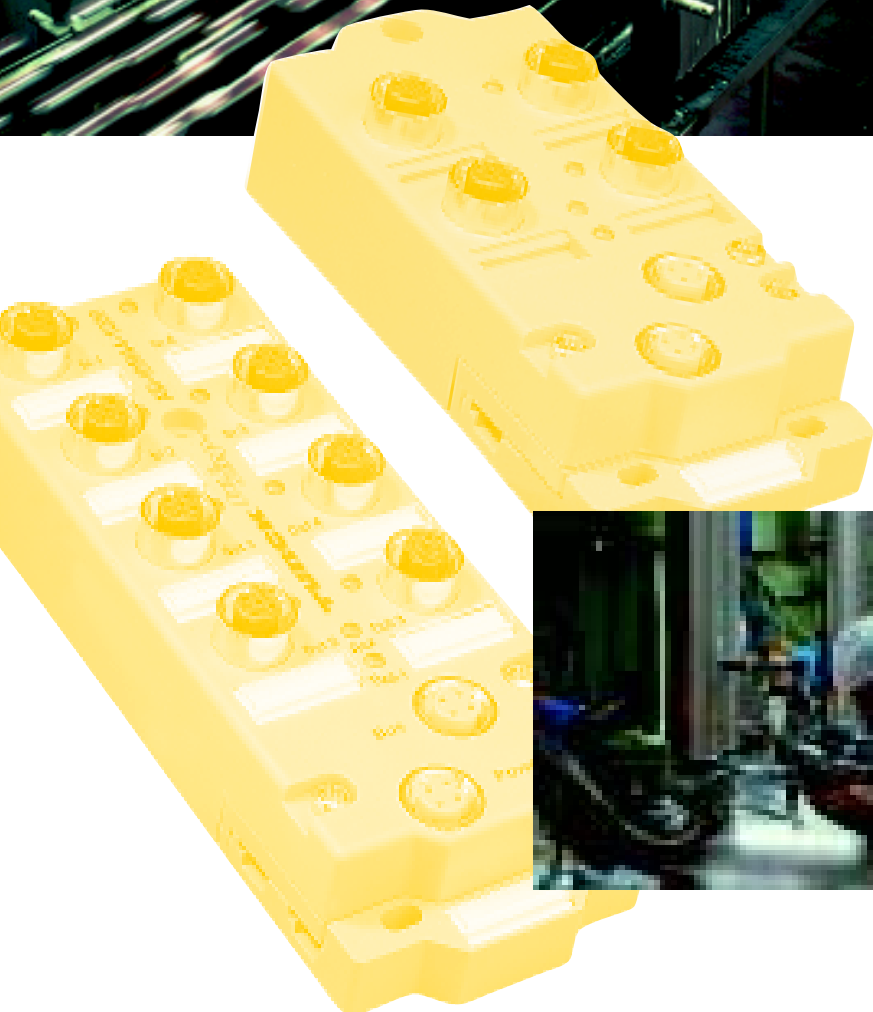

**bus
stop**®
Your fieldbus connection

AS-Interface® - System Overview

General Information

In factory automation, the 24 VDC interface is today considered the standard for networking sensors and actuators. Depending on the type of sensor, some have 2 wires (supply voltage and switching output in one such as 2-wire DC sensors), some have 3 wires (separate power supply and switching output such as 3-wire pnp sensors), or even 4 wires (power supply and output load/no load current such as some photoelectric sensors).

For added flexibility in manufacturing and to reduce down time, more and more functions have been built into the sensors: today's photoelectric sensors can switch between light operate and dark operate, they can tell you when they are getting dirty, and they have alarm messages for a variety of other conditions.

Obviously, all these functions require an additional connection point at the sensor and at the signal processor, or PLC. Three or four device connections can quickly grow into 6 or more which leads to higher installation costs. This also increases both equipment and maintenance costs. The fact that the standardized M12 connector offers a maximum of 5 connection points makes things even more complicated.

New ways had to be found to arrive at the desired functionality and, at the same time, eliminate traditional point-to-point wiring.

AS-i - The Actuator - Sensor Interface

In 1990, eleven sensor, actuator and control manufacturers formed the AS-i Association with the purpose to jointly define and develop an alternative wiring technology to replace the 24 VDC sensor and actuator interface. The goal of this association was to create an interface that provides increased functions and economical advantages.

A purely mechanical interface (wire connector) was developed simultaneously to the electronic interface (network chipsets), which allowed the user to safely and cost effectively interconnect sensors and actuators in the field.

The Association asked Siemens to come up with an **electronic interface**. They developed a special circuit (AS-i IC) that can be integrated directly into binary sensors and actuators and handles the power supply of the sensors or actuators (< 30 mA) as well as data communication. Up to 4 data lines and 4 parameter lines are available to every single IC.

Siemens and Hirschmann together have developed the **mechanical interface** for the Consortium. All accessories required for hardware configuration and networking are suited for difficult industrial environments and can be added and removed easily. The AS-i cable simply snaps on, eliminating the need for cutting and terminal strips. This provides the user with cost effective standard I/O modules for the connection of 24 VDC sensors and actuators.

The AS-i System

- gives sensors and actuators networking intelligence
- operates standard sensors/actuators via I/O modules

System installation is simple and easy: it is done by laying the AS-i bus cable and mostly premoulded sensor/actuator quick disconnect cables

Principle Of Operation And Topology

AS-i is a master-slave bus system. It supports up to 32 slave stations linked to 1 master station. A slave station is a station with an integrated AS-i IC that resides on the bus. Slaves are connected to the master with an unshielded untwisted 2-wire cable. This 2-wire cable is used for both power supply and data communication.

Every 5 ms the master sequentially calls up the connected slaves. 4 bit I/O data per slave are transmitted in each polling cycle. One master can, therefore, support up to 248 input/output points when standard input and output modules are used. The number of I/O points is reduced to a minimum of 31, when busable or intelligent sensors/actuators are connected.

Slaves can be logically connected anywhere in the system. The network interconnection is possible either in ring, bus or tree topology (see Fig. 1). It is important that the total cable length is not more than 100 m.

Power (2 A) to the bus and the connected components is supplied by the AS-i power supply unit. That makes the system reliable and data communication secure.

If additional power is required on a system, modules that provide supplementary power via M12 socket outlets can be used. Another alternative for auxiliary power is the use of the second contact point on the standard AS-i modules (see page 9).

The AS-Interface® To PLCs

Master stations have been designed with the goal of providing easy interface to programmable controllers. The PLC handles the I/O data from the master the same way it would handle I/O data from a standard I/O board. No special software programming is required for the transfer of the I/O data to the application software.

Master stations with direct access to the bus structure of various PLCs are available and other interface cards are currently being developed. Access to PCs is also available by masters with RS232 C, RS485 serial interfaces as well as direct PC interface cards.

Applications

AS-i lets the user carry out the application as before, without any software changes, using standard modular junction boxes or station enclosures as remote I/Os. This approach provides the user with all the advantages a bus system has to offer:

- drastically reduced wiring
- open system
- easy error diagnostics
- faster installation
- easier maintenance

First, cost reductions will primarily be perceived by the industrial equipment manufacturer. End users will have to make some fundamental changes in their way of thinking to take full advantage of intelligent process sensing using multifunctional sensors and actuators.

Fault Diagnosis

In conventional systems, fault or error diagnosis on the software level of the PLC is done via standardized sequential programming. Here, the operation/control software monitors and controls the process with event/time sequential programming. If a process signal is missing, the production is halted. This is an easy way to find the location of the fault but it requires a considerable amount of programming. Also, fault diagnosis is only possible once the fault has already happened.

A modern approach using sensors with embedded AS-i IC can signal in advance if a sensor may fail. This is done without increasing the amount of wire needed. In fact, this allows a reaction before the actual fault happens, for instance when the inductive sensor signals that the target has moved over time away from the safe sensing range, or that the sensor is predamped by metal dust or shavings. In fact, interruptions in the production process can thus be avoided which will cut production costs while increasing overall reliability and performance.

Operation

In addition to fault diagnosis, sensors with built-in intelligence open up new possibilities in production and can substantially reduce the number of components: for instance, inductive sensors that allow a variety of different sensing ranges or that can sense different metals without the need to exchange the sensor or the wiring. These adjustments during the production process can be made by bus communication. The same applies to photoelectric sensors.

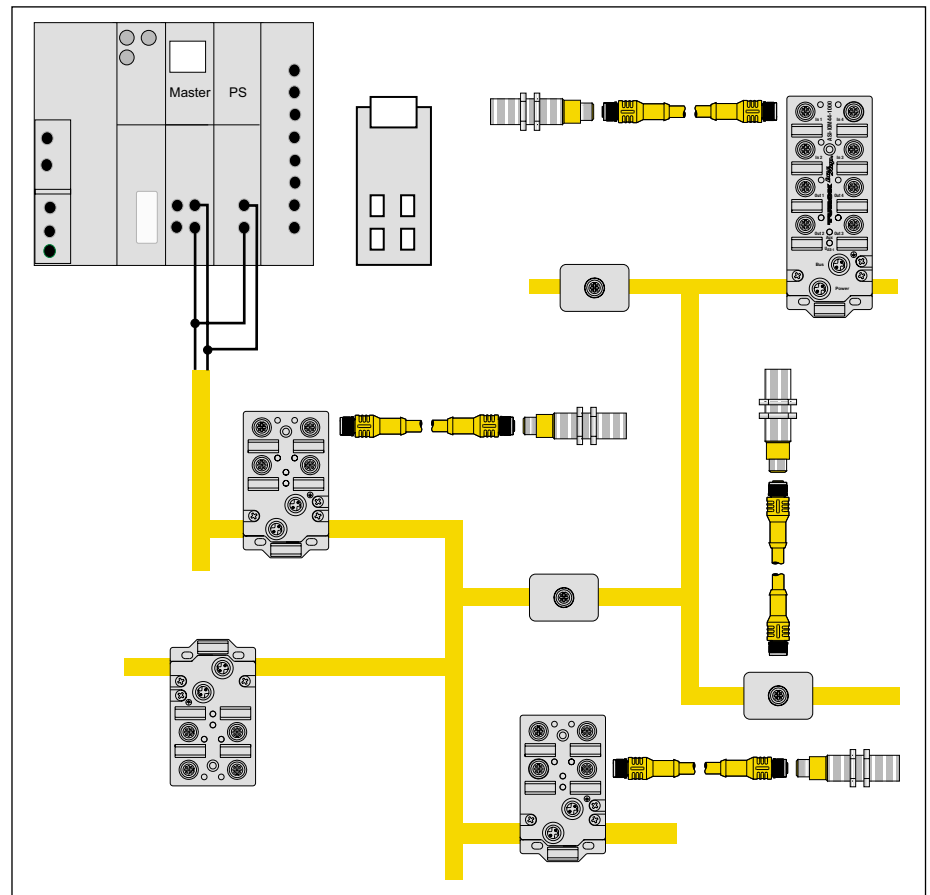

Fig. 1 Basic components for configuration of an AS-i system

In general, there are two types of inductive sensors: flush and non-flush mountable versions. Today's new sensing technologies combined with miniaturization make it now possible for non-flush mountable sensors to learn about their mounting environment through an incorporated „teach“ function. This teach function enables the sensor to work properly even under conditions that would normally generate a false activation.

AS-i provides the possibility to extend the teach function to several sensors at the same time after they have been connected to a single 2-wire cable. To use this function, the user must integrate it into the respective application software.

AS-Interface® System - Basic Components

The following components are necessary for an AS-i test system or for an application:

- **AS-i master**
available for Siemens S5 PLC, Interbus S, PCs, RS232C, RS485
- **AS-i power supply unit**
works with 31.6 VDC AS-i voltage
- **AS-i programming device**
used for programming and diagnostics of slave stations
- **AS-i stations**
active: with embedded AS-i IC for the connection of standard 24 VDC sensors and actuators
passive: without AS-i IC for the connection of sensors and actuators with embedded AS-i IC
- **AS-i sensors/actuators**
with embedded AS-i IC and additional functions
- **AS-i cable**
for use with the AS-i specific interface

AS-Interface® - Master Stations

Each AS-i master station consists of two components:

- AS-i master for polling of the slave stations; this part is identical for each master with the same profile.
- PLC specific interface, or standard serial interface

Normally, no additional software is required for a PLC master. The AS-i modules are used in the same way as standard I/O cards. For master stations with RS232 C or RS485 serial interface, a special software in the PC or PLC is needed for carrying out all functions and commands.

The Master Functions (AS-i Profile)

Depending on the application, AS-i master stations can have one of the following three performance levels (profiles):

- M0 Mini-master:
Only for I/O data exchange and configuration storage
- M1 Full master:
Provides full scale AS-i functions
- M2 Reduced master:
Full data I/O and minimum parameter programming functions

A careful analysis and evaluation of the application relative to the system is very important when choosing a master. For example, if programmable sensors/actuators are required in the application, a master with an M0 profile will not be able to handle it. Therefore, a master that conforms to the M2 profile will offer the best solution.

On the other hand, if no programming is necessary during routine operations, then the necessary adjustments can also be made with the programming device. In that case, a master according to profile M0, which is used to replace traditional parallel wiring, is also appropriate.

The AS-i system not only greatly reduces costs when compared to standard parallel wiring, it also offers the possibility to check the installation during its operation and at every restart.

To do that, the Master polls the slaves and compares the actual configuration data (AS-i system configuration) with the stored setup configuration. The user can transfer the setup configuration in the master, (for example, by downloading an existing configuration), and the data will automatically be updated with information about the bus configuration (addresses used) as well as assigned slave address and type.

According to the particular function of the slave, each one is assigned to a specific profile. The profiles define and identify the functionality of the slaves but not their physical attributes; for instance, all blocks of simple I/O modules with embedded AS-i IC are allocated in profile X.0 (X = 0...15), X indicating that the input/output configuration is different.

Device information such as module size, current load, etc. is not determined. This information is stored in non volatile memory by the manufacturer and read by the master. This is done to avoid for instance that an input module is used as an output module or as a sensor by mistake.

The fault detection capability offered by AS-i when a slave is not operating properly, is an added measure of protection because early detection and identification of problems means that corrective actions (see troubleshooting) can be taken before they lead to a break-down. This reduces downtime, and improves system performance and productivity.

System Start-Up

The start-up of an AS-i system is very simple and easy, provided some of the essential AS-i characteristics are observed.

- (1) AS-i is a master-slave bus system; therefore, an address must be assigned to each station before it is integrated into the AS-i network. No station can have the same address twice. Addressing can be done with a PC master or a programming device.

- (2) No slave with the address „0“ can be connected to the system, only when initially supplied as a replacement for a failed unit.
- (3) The maximum cable length may not exceed 100 m.
- (4) The maximum current consumption of the system is limited to 2 A.

Troubleshooting

Normally, the master recognizes and signals a fault if it occurs during normal operation, for instance, when a slave fails (sensor, actuator or module), or has a problem. The host controller can then evaluate this information.

To facilitate troubleshooting, some masters provide automatic programming functions. When this function is activated, a slave that has a problem or is destroyed can automatically be replaced by a new one having the address „0“ without having to reprogram the new slave with a programming device or similar.

Once the master recognizes that a slave has failed (by comparison with the stored setup configuration of the system; no check back from the slave), and if the information appears to be correct, then the master instantly allocates the address of the destroyed slave to the new slave via bus communication.

Special Characteristics

Some masters (RS232/RS485) have the capability to operate with standard 24 VDC. They incorporate the necessary decoupling circuitry for the AS-i network. However, it should be noted that there are cases where 24 VDC is not available everywhere in the AS-i system.

A voltage drop on the bus line and over the IC (approx. 8 V) must also be considered. If a system requires less than 24 VDC in some areas, AS-i is even more cost efficient.

AS-Interface® - Master Stations

	ASI-DEV-0001 68 211 12	ASI-MOD-0001 68 211 26	ASI-MM 485 68 211 08	ASI-MM 232 68 211 03
PLC/Bus type	DeviceNet™	Modbus Plus	serial	serial
Type of interface	Bus	Modbus Plus	RS 485	RS 232
Maximum number of HS ¹⁾ each PLC	63	32	-	-
Maximum number of ES ¹⁾ each HS	31	31	31	31
Maximum number AS ¹⁾ each HS	31	31	31	31
Maximum number ES/AS ¹⁾ each HS	31	31	31	31
Maximum number I/O each PLC	496	-	-	-
Cycle time each ES/AS ¹⁾	150 µs	150 µs	150 µs	150 µs
Housing	modular	modular	modular	modular
Dimensions W x H x D [mm]	99.7 x 110 x 75	99.7 x 110 x 75	99.7 x 110 x 75	99.7 x 110 x 75
Housing material	plastic	plastic	plastic	plastic
Degree of protection (IEC 60529/EN 60529)	IP20	IP20	IP20	IP20
Operating temperature	0 ... 55 °C	0 ... 55 °C	0 ... 55 °C	0 ... 55 °C
Diagnostic indicators	LEDs/handheld/PLC	LEDs/handheld	LEDs/handheld	LEDs/handheld
Supply voltage U_B	24 VDC (18...30 VDC)	24 VDC (18...30 VDC)	24 VDC (18...30 VDC)	24 VDC (18...30 VDC)
Maximum output current	-	-	-	-
Profile	M1	M1	M1	M1
Special features	-	-	-	-
1) Notes:				
HS = master stations				
ES = AS-i input stations				
AS = AS-i output stations				



Master Stations

	ASI-MM 232/C 68 211 09	ASI-MM 485/C 68 211 25	ASI-MOD-0001/C 68 211 27	
PLC/Bus type	serial	serial	Modbus	
Type of interface	RS232	RS485	Modbus	
Maximum number of HS ¹⁾ each PLC	-	-	32	
Maximum number of ES ¹⁾ each HS	31	31	31	
Maximum number AS ¹⁾ each HS	31	31	31	
Maximum number ES/AS ¹⁾ each HS	31	31	31	
Maximum number I/O each PLC	-	-	-	
Cycle time each ES/AS ¹⁾	150 µs	150 µs	150 µs	
Housing	modular	modular	modular	
Dimensions W x H x D [mm]	99.7 x 110 x 75	99.7 x 110 x 75	99.7 x 110 x 75	
Housing material	plastic	plastic	plastic	
Degree of protection (IEC 60529/EN 60529)	IP20	IP20	IP20	
Operating temperature	0 ... 55 °C	0 ... 55 °C	0 ... 55 °C	
Diagnostic indicators	LEDs/handheld	LEDs/handheld	LEDs/handheld	
Supply voltage U_B	24 VDC (18...30 VDC)	24 VDC (18...30 VDC)	24 VDC (18...30 VDC)	
Maximum output current	-	-	-	
Profile	M1	M1	M1	
Special features	programmable, with PLC functionality	programmable, with PLC functionality	programmable, with PLC functionality	
1) Notes:				
HS = master stations				
ES = AS-i input stations				
AS = AS-i output stations				

AS-Interface® - Stations

Basically, two groups of stations can be differentiated for the AS-i bus: The first group contains the active stations, the second group the passive junctions.

The group with the **active stations** consists of all input and output modules with the embedded AS-i chip, and provides therefore a higher level of functionality. These modules are the interface between the AS-i system and the connected sensors and actuators.

Passive junctions are used for the networking of sensors with the built-in AS-i chip, as bus junctions, or for conversion from the AS-i flat cabling system to standard round cabling. These modules are designed to help make wiring, as well as adding and removing devices simple.

Junctions and stations with AS-i specific insulation penetration technology incorporate a **base module** for connection of the AS-i specific flat cable and a **user module** with the I/O interface. All modules are designed for connection of both AS-i cables in insulation penetration technology, when the user and the base module are mounted together (additional information on base modules on page 30/31).



Fig. 2 AS-i interconnect system - input-/output module, junctions and cordsets

AS-i Standard Module (see fig. 3)

Standard user module (upper section):

- active station: for the connection of standard 24 VDC sensors and actuators
- passive junction: for the connection of sensors and actuators with embedded AS-i IC

Base module (lower section):

with AS-i specific insulation penetration technology providing terminal strip connections for AS-i flat cables.

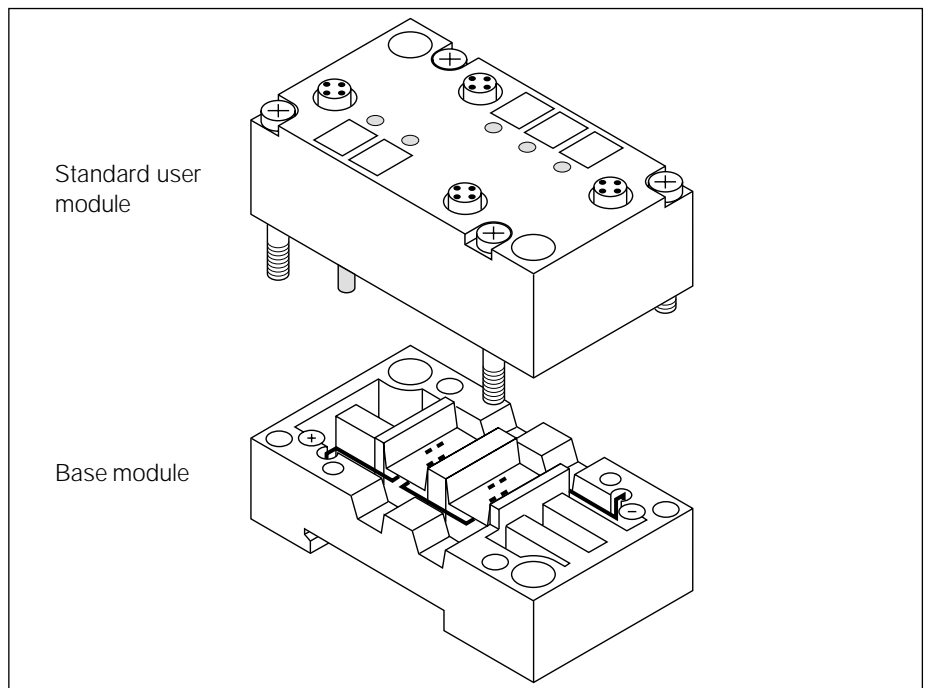

Fig. 3 AS-i standard user module (upper section) und base module (lower section)



Mechanical Characteristics

All stations give excellent environmental protection, meeting IP67 requirements; they are protected against electric shock and are dust and dirt tight. The stations pass EN 60529 standards for 30 minute immersion in water at 1 meter. The operating temperature lies between -25 and +70 °C.

There are basically two different modules available. The **AS-i standard modules** (see page 8) have a simple construction and are the inexpensive alternative for uncomplicated applications.

All connection components, such as the connector threads are made of plastic and should not be used in combination with metal connectors (the threads can then be easily damaged). These modules are not potted, so that when they are exposed to rapid temperature changes and high humidity, they require extra protection against penetration of moisture (absorption effect).

In contrast to this, the **TURCK modules** (see page 10) are far more complex and provide a variety of features:

- **full potting**
- **metal connectors**
- **connection of flat and round cables**

These design features prevent penetration of moisture, even under conditions where temperatures change rapidly, and avoid disconnection difficulties due to damaged threads. As it is possible to connect flat cables as well as round cables via the standardised M12 connector system *eurofast*[®], it is easy to switch from one technology to the other. Bus cabling is facilitated significantly; and for special application requirements there are a variety of cable qualities available (e.g. high temperature resistant cables for welding applications, highly flexible cables for applications where they are subject to frequent movement). The standard M12 connectors are also of great help as an isolating point in error identification.

Active Stations Electrical Characteristics

Power to the active modules on the system is supplied through the bus voltage. The available voltage ranges from 29.5 to 31.5 V when measured directly behind the AS-i power supply unit, but can drop by 3 V at the end of a 100 m long AS-i flat cable.

Some modules also supply connected field devices such as sensors directly through the system supply voltage or directly through the AS-i chip. The internal voltage drop in the AS-i chip is 6 V, so there is a 25.6...20.5 V sensor/actuator voltage range available to the connected field devices. The maximum current that can flow through the AS-i chip is 30 mA.

In order to reduce the strain on the AS-i line, many modules enable use of the second AS-i connection point for additional power supply. The AS-i standard stipulates use of a black cable to avoid interchange errors with the yellow bus cable (for applications with 230 VAC the use of a red cable is mandatory). The **TURCK modules** provide connection of the additional power supply via M12 *eurofast*[®] connectors. All stations are designed in such a way that polarity reversal or a short-circuit will interrupt the bus communication for a short time only. Replacements can be made even while the system is operating.

Please note: An indication of a faulty sensor/actuator or of a cable wire-break is not available with the 4-channel input and the 4-channel input/output modules, because there are no data areas available for this on the bus. With some of the 2-channel modules and the pure output modules, some of the bits, which are not used for I/O data, are used for diagnosis purposes (see resp. operation manuals). With most modules, a short-circuit indication from the field (sensor/actuator or supply line) is received by means of withdrawal of one of the modules from the list of the active stations (evaluation depends on master type).

Passive Stations/Junctions

Features

Passive stations are available in a variety of designs, e.g. based on the standard AS-i module, featuring 1...4 channels and consisting of the user and the base module, or a small clip module which enables connection of a single sensor/actuator with integrated chip (basically, this clip device serves for converting the specific AS-i connection technique to M12 connections).

AS-i Printed Circuit Boards

For customer-specific applications or for integration of your device, such as drives or power clamps, TURCK offers AS-i printed circuit boards with different configurations.

Addressing

Addressing of the stations is carried out by the AS-i handheld or a PC with the appropriate software and the AS-i interface. Addressing must always be accomplished before the initial system start-up. Please observe that one address may only be present once within the entire system.

Attention: The address 0 may not be used.

Diagnosis Functions

All stations are equipped with LEDs for status and bus supply voltage indications. Communication with the bus master is not indicated. The AS-i handheld serves for system diagnosis. Some master types provide the complete range of diagnosis indications. The user is responsible for the evaluation level.

AS-Interface® - Stations

Active Input Stations

Input stations are used to receive binary process signals from hardwired field devices. The input data are scanned by the master station in a cyclic manner. To assure that the system operates properly, each station must be assigned a specific address.

A variety of standard pnp sensors can be connected to the inputs. For all of them applies the same:

- power supply through the bus cable
- total current draw ≤ 150 mA
- operating voltage 10...30 VDC

Devices that can be connected to the active input stations are:

- 3-wire pnp sensors
- 2-wire sensors
- potential-free contacts

The connections are made with *eurofast*® connectors. When using sensors with increased current consumption such as some photoelectric sensors or flow controls, the max. load supply must be strictly observed. Too high current draws may impair the system function.

Alongside the modules featuring protection type IP67, there are also screw terminal versions with protection type IP20 available. These are suitable for cabinet mounting.

The „pneumatic“ module serves a very specific purpose as it incorporates magnetic valves for direct control of drives or cylinders.

AS-i printed circuit boards for integration of your devices are adapted to the specific application. No matter if the number of I/O points, the kind of I/Os, or the mechanical designs are concerned, your wishes can be put into practice. Just ask us.

Attention: With some of the modules, the connectors 2 and 4 are bridged (see operation instructions). This enables connection of normally open and normally closed sensors, but the use of complementary sensors is not permitted.

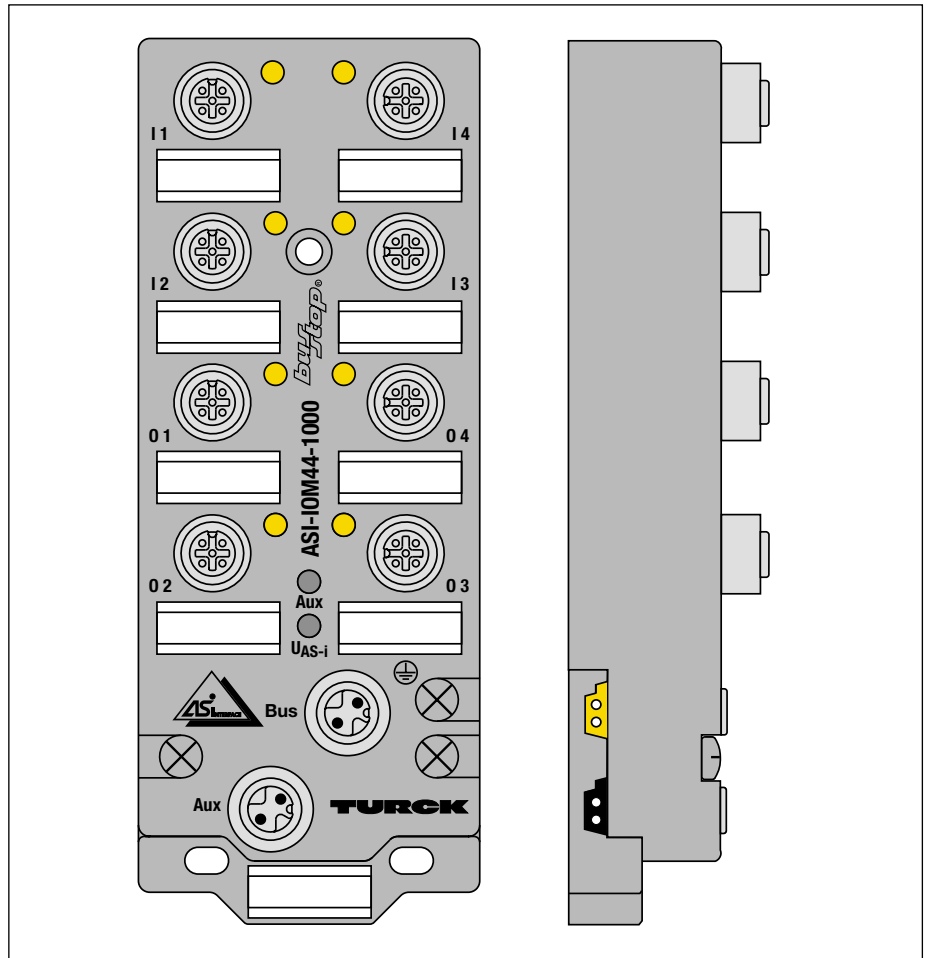

Fig. 4 TURCK AS-i input/output module

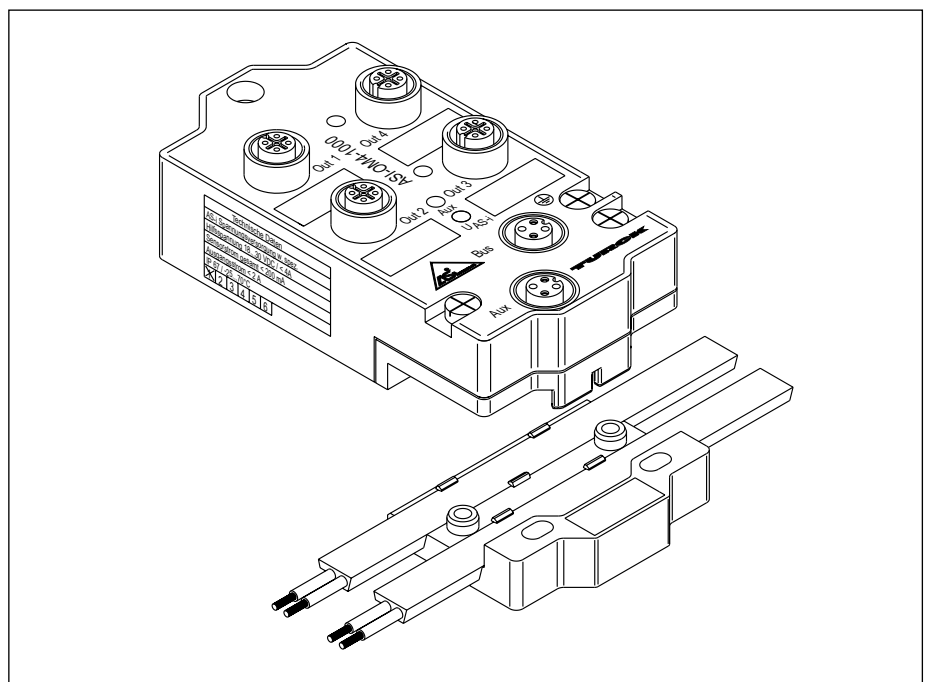

Fig. 5 TURCK connection technology

● **Active Input Stations**
2 channels/4 channels

	ASI-IM 41 68 213 01	ASI-IM 4-1000 68 213 16		
Description	input station 4 channels	input station 4 channels		
Supply voltage per AS-i specification No load current/total current	29.5... 31.5 V - / 120 mA	29.5... 31.5 V - / 120 mA		
Input Data				
Sensor voltage	U _{AS-i}	U _{AS-i}		
Total sensor current	100 mA	200 mA		
Switching frequency	-	-		
Channels	4	4		
Short-circuit protection	●	●		
Galvanic isolation	-	-		
Output Data				
Output voltage	-	-		
Output current/each channel	-	-		
Switching frequency	-	-		
Channels	-	-		
Short-circuit protection	-	-		
Galvanic isolation	-	-		
AS-I Specifications				
AS-i Profile	0.0	0.0		
Data bit 0 connector/active pin	1/2 + 4	1/2 + 4		
Data bit 1 connector/active pin	2/2 + 4	2/2 + 4		
Data bit 2 connector/active pin	3/2 + 4	3/2 + 4		
Data bit 3 connector/active pin	4/2 + 4	4/2 + 4		
Safety Measures				
Reverse polarity protection	●	●		
Short-circuit protection	●	●		
Mechanical Characteristics				
Housing material	PBT	PA6-GF30		
Dimensions W x H x D [mm]	80 x 45 x 27	119 x 60 x 35		
Degree of protection (IEC 60529/EN 60529)	IP67	IP67		
Temperature range	-25... +70 °C	-25... +70 °C		
Mounting	screws/hat rail	screws/hat rail		
Bus connection	to AS-i specification	to AS-i specification		
Connection to sensors/actuators	euromast®	euromast®		
External power supply	euromast®	flat cable/euromast®		
Module type	AS-i standard module	TURCK module		
Diagnosis				
- Status indication	4 LEDs	4 LEDs		
- AS-I voltage	LED	LED		

AS-Interface® - Stations

- Active Input/Output Stations
2 channels/4 channels
- Passive Junctions
1 channel/4 channels

	ASI-IOM 221 68 213 03	ASI-IOM 441-0001 68 213 09	ASI-IOM 44-1000 68 213 13	ASI-IOM 441-0002 68 213 10
Description	input/output station 2/2 channels	input/output station 4/4 channels	input/output station 4/4 channels	input/output station 4/4 channels
Supply voltage per AS-I specification	29.5...31.5 V	29.5...31.5 V	29.5...31.5 V	29.5...31.5 V
No load current/total current	- /120 mA	- /270 mA	50/250 mA	- /270 mA
Input Data				
Sensor voltage	U _{AS-I}	U _{AS-I}	U _{AS-I}	U _{AS-I}
Total sensor current	100 mA	200 mA	200 mA	159 mA
Switching frequency	-	-	-	-
Channels	2	4	4	4
Short-circuit protection	●	●	●	●
Galvanic isolation	-	-	-	-
Output Data				
Output voltage	contact	electronic	electronic	electronic
Output current/each channel	-	24 VDC	24 VDC	24 VDC
Output current/each channel	500 mA	2 A	2 A	1 A
Switching frequency	-	-	-	-
Channels	2	4	4	4
Short-circuit protection	-	●	●	●
Galvanic isolation	-	-	●	-
AS-i Specifications				
AS-i Profile	3.0	7.0	7.0	7.0
Data bit 0 connector/active pin	1/2 + 4	in 1/4 - out 1/4	in 1/2 + 4 - out 1/4	in 1 - out 1
Data bit 1 connector/active pin	2/2 + 4	in 2/4 - out 2/4	in 2/2 + 4 - out 2/4	in 2 - out 2
Data bit 2 connector/active pin	3/4	in 3/4 - out 3/4	in 3/2 + 4 - out 3/4	in 3 - out 3
Data bit 3 connector/active pin	4/4	in 4/4 - out 4/4	in 4/2 + 4 - out 4/4	in 4 - out 4
Safety Measures				
Reverse polarity protection	●	●	●	●
Short-circuit protection	-	-	●	-
Mechanical Characteristics				
Housing material	PBT	PBT	PA6-GF30	PBT
Dimensions W x H x D [mm]	80 x 45 x 27	152 x 60 x 31	156 x 60 x 35	90 x 75 x 37
Degree of protection (IEC 60529/EN 60529)	IP67	IP67	IP67	IP20
Temperature range	-25... +70 °C	-25... +70 °C	-25... +70 °C	-25... +70 °C
Mounting	screws/hat rail	screws	screws	hat rail
Bus connection	to AS-i specification	to AS-i specification	to AS-i specification	terminals
Connection to sensors/actuators	euromast®	euromast®	euromast®	screw terminals
External power supply	euromast®	to AS-i specification	to AS-i specification	terminals
Module Type	AS-i standard module	-	TURCK module	-
Diagnosis				
- Status indication	4 LEDs	8 LEDs	8 LEDs	8 LEDs
- AS-i voltage	LED	2 LEDs	2 LEDs	LED

<i>ASI-IOM 22-1000</i> 68 213 14	<i>ASI-IOM 44-1001</i> 68 213 19	<i>ASI-IOM 22-0003</i> 	<i>ASI-PM 11</i> 68 214 01	<i>ASI-PM 41</i> 68 214 02	
input/output station 2/2 channels	input/output station 4/4 channels	input/output station 2/2 channels	passive junction 1 channel	passive junction 4 channels	
29.5...31.5 V	29.5...31.5 V	29.5...31.5 V	29.5...31.5 V	29.5...31.5 V	
50/250 mA	50/250 mA	5- /200 mA	- / -	- / -	
U _{AS-i} 200 mA	U _{AS-i} 200 mA	U _{AS-i} 100 mA	-	-	
-	-	-	-	-	
2	4	2	1	4	
●	●	●	-	-	
-	-	-	-	-	
electronic 24 VDC 2 A	electronic 24 VDC 500 mA	valve/pneumatic 24 VDC	-	-	
-	-	-	-	-	
2	4	2	1	-	
●	●	-	-	-	
●	●	-	-	-	
7.0	3.F	7.0	-	-	
in 1/2 + 4	-	-	-	-	
in 2/2 + 4	-	-	-	-	
out 3/4	-	-	-	-	
out 4/4	-	-	-	-	
●	●	●	●	●	
-	-	-	-	-	
PA6-GF30 119 x 60 x 35 IP67 -25... +70 °C screws to AS-i specification <i>eurofast</i> [®] to AS-i specification	- - IP20 -25... +70 °C printed circuit board -	PBT 80 x 45 x 27 IP65 -25... +70 °C screws/hat rail to AS-i specification <i>eurofast</i> [®] pneumatic tube	- 50 x 20 x 30 IP67 -25... +70 °C screws to AS-i specification <i>eurofast</i> [®]	PBT 90 x 45 x 27 IP67 -25... +70 °C screws/hat rail to AS-i specification <i>eurofast</i> [®] -	
TURCK module	TURCK module	AS-I standard module	AS-I standard module	AS-I standard module	
4 LEDs 2 LEDs	LEDs LED	4 LEDs LED	- -	- -	

AS-Interface® - Stations

Active Output Stations

Output stations transmit binary process signals to the connected actuators. The data received from the master station are stored in the output station and transferred to the switching outputs.

Each output station provides an additional connector for the required power. During a power failure, or when a break in the bus cable occurs, all outputs are securely shut down (0).

Various actuators can be connected to the output:

- valves
- relays
- annunciators

All of them must have the following attributes:

- supply voltage: 24 VDC
- current per output: 1 A

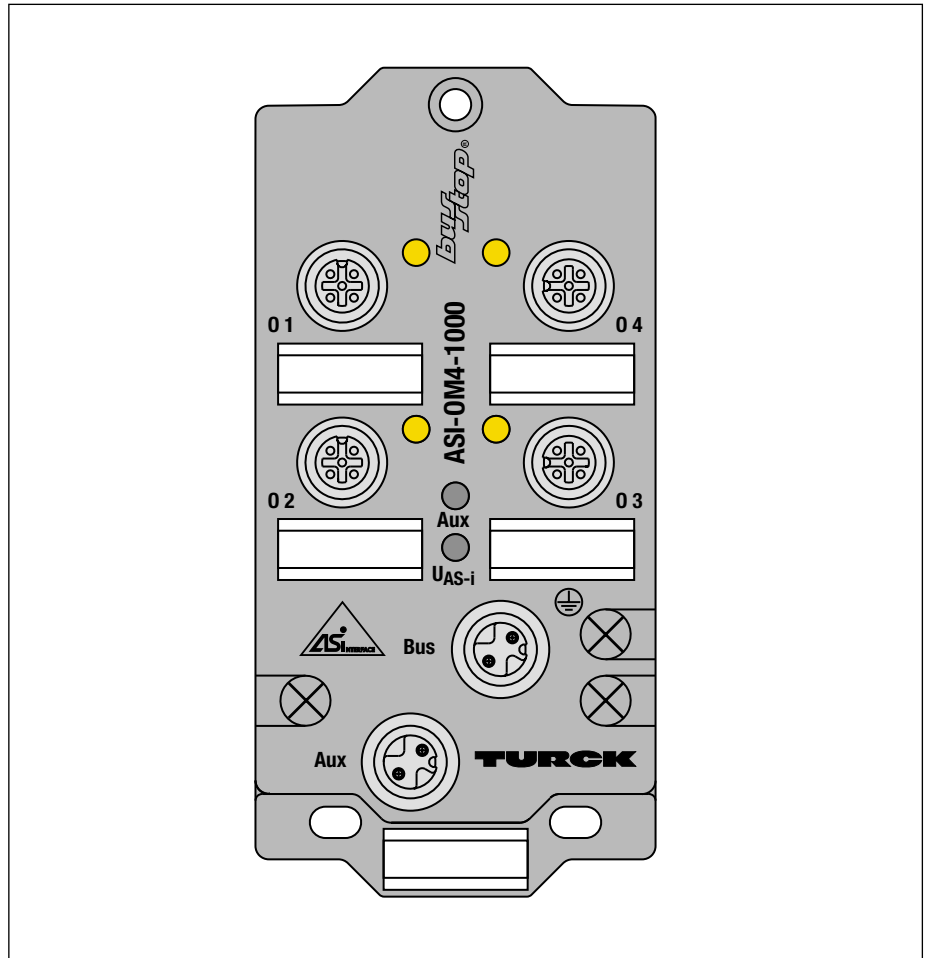

Fig. 6 TURCK AS-i output module

● **Active Output Stations**
4 channels

	ASI-OM 41 68 213 04	ASI-OM 4-1000 68 213 15		
Description	output station 4 channels	output stations 4 channels		
Supply voltage per AS-i specification	29.5.. 31.5 V	29.5.. 31.5 V		
No load current/total current	- /60 mA	50 mA /-		
Input Data				
Sensor voltage	-	-		
Total sensor current	-	-		
Switching frequency	-	-		
Channels	-	-		
Short-circuit protection	-	-		
Galvanic isolation	-	-		
Output Data	contact	electronic		
Output voltage	-	24 VDC		
Output current/each channel	1 A	2 A		
Switching frequency	-	-		
Channels	4	4		
Short-circuit protection	-	●		
Galvanic isolation	●	●		
AS-i Specifications				
AS-i Profile	8.0	8.0		
Data bit 0 connector/active pin	1/4	1/4		
Data bit 1 connector/active pin	2/4	2/4		
Data bit 2 connector/active pin	3/4	3/4		
Data bit 3 connector/active pin	4/4	4/4		
Safety Measures				
Reverse polarity protection	●	●		
Short-circuit protection	-	●		
Mechanical Characteristics				
Housing material	PBT	PA6-GF30		
Dimensions W x H x D [mm]	80 x 45 x 27	119 x 60 x 35		
Degree of protection (IEC 60529/EN 60529)	IP67	IP67		
Temperature range	-25.. +70 °C	-25.. +70 °C		
Mounting	screws/hat rail	screws		
Bus connection	to AS-i specification	to AS-i specification or <i>eurofast</i> [®]		
Connection to sensors/actuators	<i>eurofast</i> [®]	<i>eurofast</i> [®]		
External power supply	<i>eurofast</i> [®]	to AS-I specification or <i>eurofast</i> [®]		
Module type	AS-i standard module	TURCK module		
Diagnosis				
- Status indication	LED	4 LEDs		
- AS-i voltage	LED	2 LEDs		

AS-Interface® - Inductive Sensors

- Integrated AS-Interface®
- *uprox*® all metal sensors without correction factor
- 5... 75 mm switching distance for all metals



Fig. 7 Inductive sensors with integrated AS-i chip

What's a *uprox*® ?

Like all inductive proximity switches, *uprox*® sensors are non-contact, wear-free sensors designed to detect metal targets. In addition, due to their special ferrite-less 3-coil construction, they incorporate features which provide them with significant advantages for a wide range of applications compared to conventional sensors:

Factor 1

uprox® sensors detect all metals with the same reduction factor, i. e. the sensing range is the same for all metals.

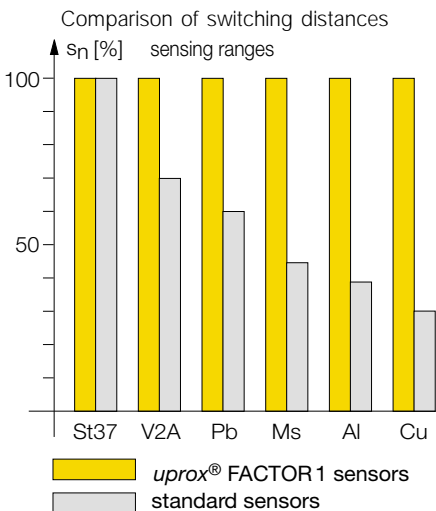

Standard Magnetic Field Immunity

As there is no ferrite core, *uprox*® sensors are not affected by strong electromagnetic AC or DC fields.

Extended Sensing Range

The sensing range of most of the *uprox*® sensors with a target made of mild steel is considerably greater than that of equivalent conventional inductive sensors and can be up to 100 % more, depending on the sensor used. The difference is even greater for non-ferrous target materials.

Large switching distance

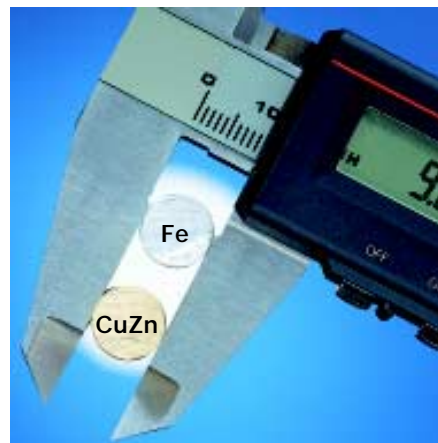

Extended Temperature Range

uprox® sensors have an operating temperature range of -30... +85 °C. The temperature drift per DIN EN 50008 is maximal ±10 % in the range from -25...+70 °C. In the standard temperature range from -30... +85 °C, the temperature drift is up to ±15 %.

High Switching Frequency

uprox® sensors contain special sensor coils, giving them a switching frequency significantly faster than that of conventional inductive proximity sensors.

Magnetic field immune

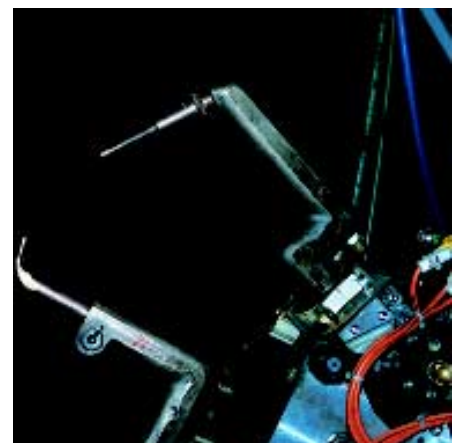



Protection Arrangements

uproX[®] sensors are protected not only against submersion in water (IP67), but also against extreme environmental conditions, e.g. temperature cycling (common in the food industry). In addition to this, *uproX*[®] sensors correspond to protection class 2 (as indicated by the symbol for insulation class equipment).

Housing Material

In addition to the chrome plated brass barrel, the threaded barrel *uproX*[®] is available in two further versions:

The stainless steel threaded barrel is especially resistant against chemical reaction, e.g. cleaning processes in the food industry. A welding proof version with teflon coating is also available. This offers protection against sparks flying and weld splatter as experienced in car body welding in automotive plants.

One Sensor - Many Applications

Due to the many inherent extra features, *uproX*[®] sensors offer considerable advantages, particularly for applications that previously required special purpose sensors. Higher performance at no extra cost:

- for general applications:
(eg. rotational speed monitoring):
chrome plated brass housing
- for applications in the material handling and conveyor industry:
CK40, CP40, CP80 plastic housing
- for applications in the food and beverage industry:
stainless steel barrel housing
- for welding operations:
teflon-coated brass barrel housing
and/or teflon-coated cap

uproX[®] Sensors With Embedded AS-i Chip

uproX[®] sensors with incorporated networking capability through the AS-i chip connect to the AS-i bus via a passive junction box (such as ASI-PM21-VB1). These sensors use an embedded AS-i IC to communicate with the PLC.

AS-Interface® - Inductive Sensors





- Cylindrical metal housing
M 18 x 1, M 30 x 1,5
- Rectangular plastic housing
40 x 40, 80 x 80

Bi5U-M18-ASIX-
H1140
19 010 04

Ni12U-M18-ASIX-
H1140
19 010 05

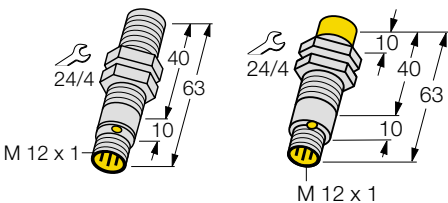
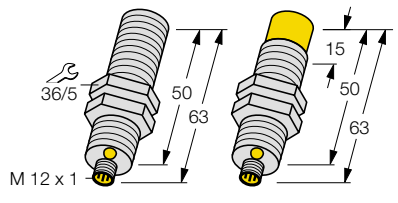
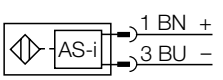
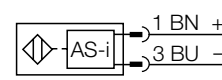
Bi10U-G30-ASIX-
H1140
19 010 01

Ni20U-G30-ASIX-
H1140
19 010 06

Connection	euromast® DC		euromast® DC	
	Electrical version		Electrical version	
Dimensions	<p>M 18 x 1</p> 		<p>M 30 x 1,5</p> 	
Wiring diagram				
Sensing Distance s_n [mm]	5	12	10	20
Flush mounting (f), non-flush (nf)	f	nf	f	nf
Supply voltage U_B [V]	18...33 VDC	18...33 VDC	18...33 VDC	18...33 VDC
No-load current [mA]	≤ 30	≤ 30	≤ 30	≤ 30
AS-I Profile	1.1	1.1	1.1	1.1
Data bit 0	switching signal	switching signal	switching signal	switching signal
Data bit 1	-	-	-	-
Data bit 2	-	-	-	-
Data bit 3	-	-	-	-
Switching frequency [Hz]	200 ¹⁾	200 ¹⁾	200 ¹⁾	200 ¹⁾
Switching hysteresis [%]	3... 15	3... 15	3... 15	3... 15
Temperature drift [%]	± 10	± 10	± 10	± 10
Repeat accuracy [%]	≤ 2	≤ 2	≤ 2	≤ 2
Material housing	CuZn, chrome-plated	CuZn, chrome-plated	CuZn, chrome-plated	CuZn, chrome-plated
Material active face	PA12-GF30	PA12-GF30	PA12-GF30	PA12-GF30
Material end cap	PUR	PUR	PUR	PUR
Degree of protection (IEC 60529/EN 60529)	IP67	IP67	IP67	IP67
Insulation class (EN 60947-5-2 Annex B)	totally insulated 2 	totally insulated 2 	totally insulated 2 	totally insulated 2 
Operation temperature [°C]	-25...+70	-25...+70	-25...+70	-25...+70
Fixing torque [Nm]	25	25	90	90
Cable/clamping ability/connector [mm]	euromast®	euromast®	euromast®	euromast®
Output indication	LED	LED	LED	LED
Power on indication	-	-	-	-

¹⁾ A fully configured bus system will reduce the switching frequency accordingly.

*Bi15U-CK40-ASIX2-
H1140
19 010 02*

*Ni25U-CK40-ASIX2-
H1140
19 010 07*

*B15U-CP40-ASIX2
19 010 03*

*Ni40U-CP40-ASIX2
19 010 08*

*Ni75U-CP80-ASIX2
19 010 10*

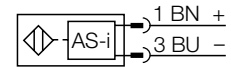
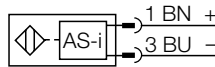
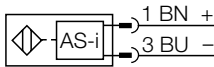
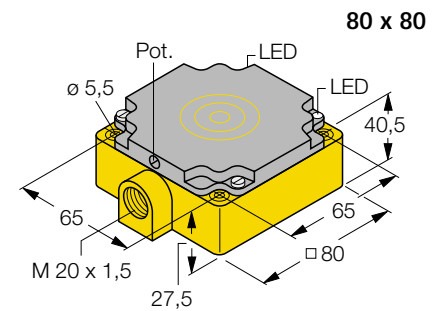
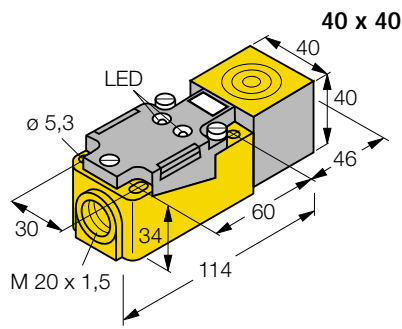
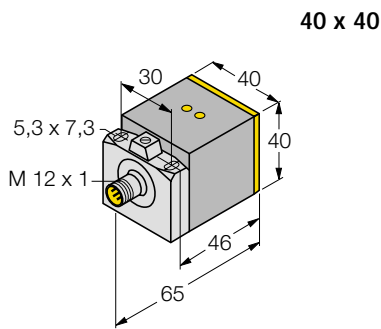

AS-Interface® - Photoelectric Sensors

- Integrated AS-i chip
- All operating modes
- EASY-BEAM sensors with alarm output via AS-i bus
- Family Q45 with alarm output, light-/dark operate selection, change of modulation frequency etc. via AS-i bus

Operating Principle

A photoelectric sensor is a device which detects a visible or invisible beam of light. The sensor emits light pulses that are detected either by the same sensor or by a separate light receiver. A switching signal is generated by the amount of light received, depending on the sensing mode.

Sensing Modes

Opposed Mode Sensors

consist of an emitter and receiver in two separate housings. An object is detected when it interrupts the light beam between the transmitter and the receiver.

Retroreflective Sensors

contain both the emitter and receiver in one housing. The emitter sends out a light beam which is reflected by the reflector and picked up by the receiver. An object is detected when it interrupts this light beam.

Diffuse Mode Sensors

combine both emitter and receiver in one housing. Light emitted by the sensor is reflected by the target and sensed by the receiver.

Diffuse Mode Sensors With Background Suppression

operate according to the same principle as diffuse mode sensors but they also eliminate the influence of background objects, even if the objects are very reflective.

Fiberoptic Sensors

use glass or plastic fibres to conduct the sensing light close to the target.



Fig.8 Photoelectric and ultrasonic sensors with integrated AS-interface

Light And Dark Operating Mode

A light operating sensor is a photoelectric sensor that produces a switching signal when the receiver senses sufficient light. Dark operating sensors are those that produce a switching signal when no light is received.

Alarm Output

Photoelectric sensors perform properly only when they detect enough light. Objects are no longer reliably sensed when light is lost because of material build-up on the lenses or the reflector, a common problem when installed in a dirty location. The alarm output in photo-electric sensors alerts the user before the sensor fails that the light beam is obscured or contaminated.

Photoelectric Sensors With Embedded AS-i Chip

EASY-BEAM Family

Each sensor is available in three different housing styles:

- S Pack: straight threaded barrel housings
- T Pack: short barrel sensors
- Q Pack: rectangular housings

All sensors are equipped with a 30 mm thread for mounting.

EASY-BEAM photoelectric sensors use their bus capability to transmit whether they are on or off, or to send an alarm signal to indicate that the existing operating parameters have made the sensor unreliable.

With EASY-BEAM sensors, the selection between light or dark operate is also done via bus communication by the parameter bit.

Q45 Sensors

These devices use three data bits and parameter bits for the communication with the PLC. The data bits transmit the switching status, warn for too low excess gain or perform a sensor test.

With the help of the parameter bits one can choose between light- and dark operate, change the output to a one shot output or prevent mutual interference of two sensors by changing the modulation frequency.

Excess Gain Curves

Curve 1: S30/T30/Q40-X21-LP-Q

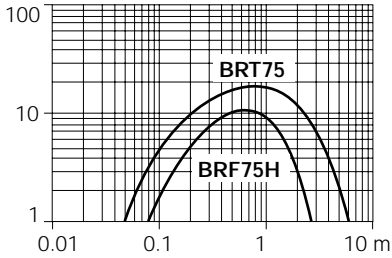

Curve 2: S30/T30/Q40-FF...

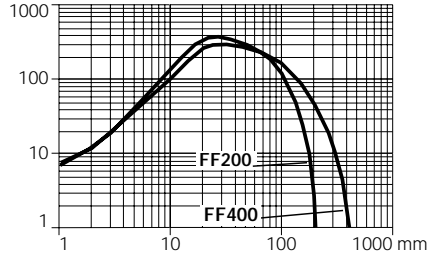

Curve 3: Q45XAS1-L...-Q

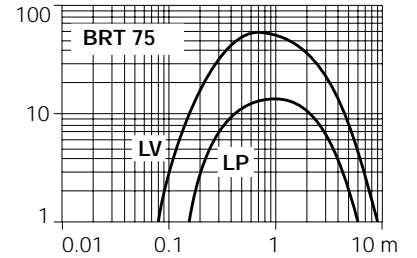

Curve 4: Q45-XAS1-D...-Q

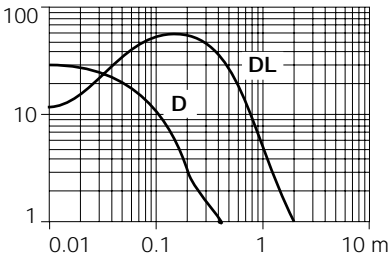

Curve 5: Q45-XAS1-CV...-Q

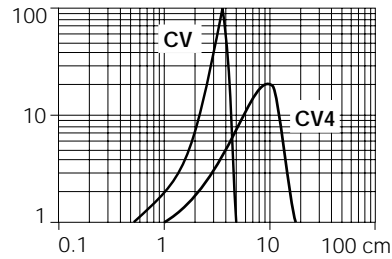

Curve 6: Q45-XAS1-E/R-Q

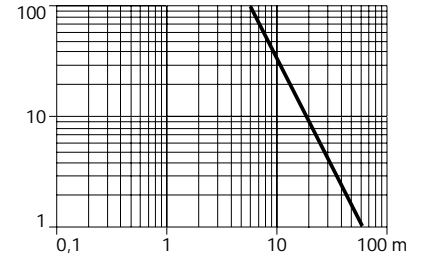



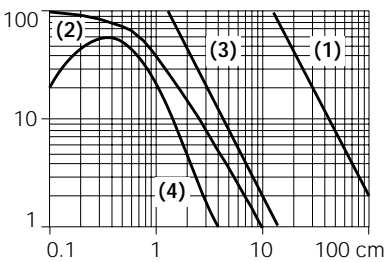

Curve 7: Q45-XAS1-F...-Q



- (1) Q45...F with IT23SM8
- (2) Q45...F with BT23SM8
- (3) Q45...FP with PIT46U
- (4) Q45...FP with PBT46U

AS-Interface® - Photoelectric Sensors

- Family EASY-BEAM, types S30, T30, Q40 with *euromast*® connectors

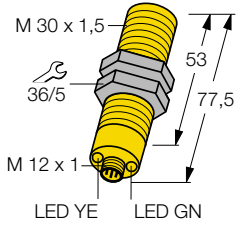
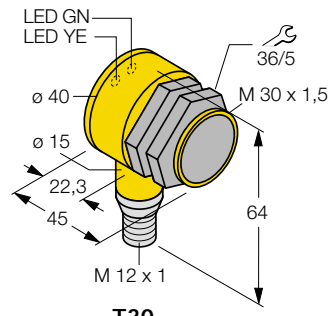
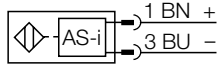
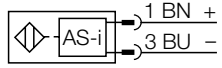
	S30-X21-LP-Q 34 730 00	T30-X21-LP-Q 34 733 00	Q40-X21-LP-Q 34 736 00	S30-X21-FF200-Q 34 737 00	T30-X21-FF200-Q 34 734 00	Q40-X21-FF200-Q 34 737 00
Connection	 euromast® DC			 euromast® DC		
Electrical version	 euromast® DC			 euromast® DC		
Dimensions	 <p>S30...</p>			 <p>T30...</p>		
Wiring diagram						
Max. sensing range [m]	6			0.2		
Excess gain curve	page 21, curve 1			page 21, curve 2		
Sensing mode	retroreflective			fixed field		
Connection	<i>euromast</i> ®			<i>euromast</i> ®		
Light source	red			IR		
Wave length [nm]	680			880		
Adjustments						
Sensitivity	-			-		
Light-/dark operate	via the bus			via the bus		
Supply voltage U _B [VDC]	18... 33			18... 33		
No-load current [mA]	≤ 35			≤ 40		
AS-i Profile	1.1			1.1		
Data bit 0	switching signal			switching signal		
Data bit 1	alarm signal			alarm signal		
Switching frequency [Hz]	170 ¹⁾			170 ¹⁾		
Material housing	VALOX (PBT)			VALOX (PBT)		
Material lens	Acryl			Acryl		
Material end cap/terminal chamber	-			-		
Degree of protection (IEC 60529/EN 60529)	IP65			IP65		
Operating temperature [°C]	-25...+70			-25...+70		
Cable /clamping ability [mm]	-			-		
Switching status indication	LED			LED		
Power on indication	LED			LED		
Warning (low excess gain)	LED, flashing			LED, flashing		

¹⁾ A fully configured bus system will reduce the switching frequency respectively

S30-X21-FF400-Q
34 732 00

T30-X21-FF400-Q
34 735 00

Q40-X21-FF400-Q
34 738 00

euromast®
DC

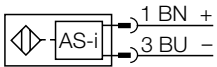
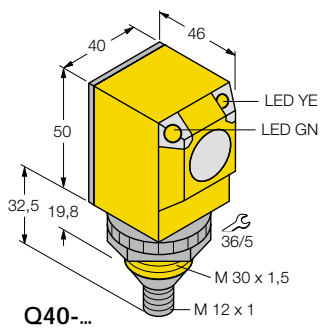

0.4
page 21, curve 2

fixed field
euromast®
IR
880

-
via the bus

18... 33
≤ 40

1.1
switching signal
alarm signal

170¹⁾



VALOX (PBT)
Acryl

-
IP65
-25...+70

-
LED
LED
LED, flashing

AS-Interface® - Photoelectric Sensors

- Type Q45
with *eurofast*® connector

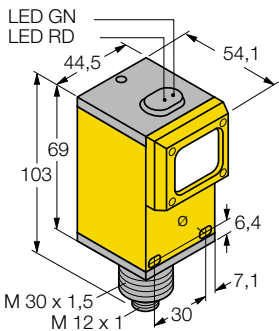
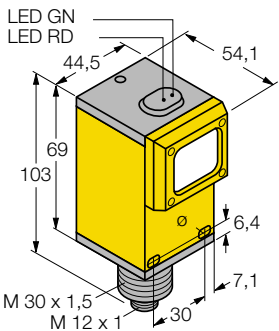
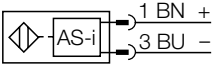
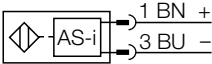
		Type Ident.-No.	Q45-XAS1-LV-Q 30 407 79	Q45-XAS1-LP-Q 30 407 78 polarisation filter	Q45-XAS1-D-Q 30 400 56	Q45-XAS1-DL-Q 30 407 77
Connection		 eurofast DC		 eurofast DC		
Electrical version						
Dimensions						
Wiring diagram						
Max. sensing range	[m]	0.08...9	0.15...6	0.45	1.8	
Excess gain curve		page 21, curve 3		page 21, curve 4		
Sensing mode		retroreflective		diffuse		
Connection		<i>eurofast</i> ®		<i>eurofast</i> ®		
Light source		red		IR		
Wave length		[nm]	680	880		
Adjustments		on sensor		on sensor		
Sensitivity		on sensor / via bus		on sensor / via bus		
Supply voltage U _B		[VDC]	18... 33	18... 33		
No-load current		[mA]	≤ 45	≤ 45		
AS-i Profile		1.1		1.1		
Data bit 0		light sensed		light sensed		
Data bit 1		warning (low excess gain)		warning (low excess gain)		
Data bit 3		sensor test, disable emitter		sensor test, disable emitter		
Parameter bit 0		change of modulation frequency		change of modulation frequency		
Parameter bit 1		light-/dark operate		light-/dark operate		
Parameter bit 2		off delay, 20 ms		off delay, 20 ms		
Switching frequency		[Hz]	250 ¹⁾	250 ¹⁾		
Material housing		VALOX® (PBT)		VALOX® (PBT)		
Material lens		Acryl		Acryl		
Material end cap/terminal chamber		Lexan® (PC)		Lexan® (PC)		
Degree of protection (IEC 60529/EN 60529)		IP67		IP67		
Operating temperature		[°C]	-25...+70	-25...+70		
Switching status indication		LED		LED		
Indication light sensed		LED		LED		

1) A fully configured bus system will reduce the switching frequency respectively

<p style="writing-mode: vertical-rl; transform: rotate(180deg);">Q45-XAS1-CV4-Q 30 407 84</p>	<p style="writing-mode: vertical-rl; transform: rotate(180deg);">Q45-XAS1-CV4-Q 30 407 85</p> <p style="writing-mode: vertical-rl; transform: rotate(180deg);">Q45-XAS1-E-Q 30 407 80</p>	<p style="writing-mode: vertical-rl; transform: rotate(180deg);">Q45-XAS1-R-Q 30 407 81</p> <p style="writing-mode: vertical-rl; transform: rotate(180deg);">Q45-XAS1-F-Q 30 407 82</p> <p style="writing-mode: vertical-rl; transform: rotate(180deg);">Q45-XAS1-FP-Q 30 407 83</p>
<p style="text-align: center;"> eurofast® DC</p>	<p style="text-align: center;"> eurofast® DC</p>	<p style="text-align: center;"> eurofast® DC</p>
<p>0.038 0.1 page 21, curve 5</p>	<p>60 page 21, curve 6</p>	<p>- - page 21, curve 7</p>
<p>convergent <i>eurofast®</i> red 680</p>	<p>emitter receiver <i>eurofast®</i> IR 880</p>	<p>glass fibre plastic fibre <i>eurofast®</i> IR red 880 660</p>
<p>on sensor on sensor / via bus 18... 33 ≤ 45</p>	<p>on sensor on sensor / via bus 18... 33 ≤ 45</p>	<p>on sensor on sensor / via bus 18... 33 ≤ 45</p>
<p>1.1 light sensed warning (low excess gain) sensor test, disable emitter change of modulation frequency light-/dark operate off delay, 20 ms</p>	<p>1.1 light sensed warning (low excess gain) sensor test, disable emitter change of modulation frequency light-/dark operate off delay, 20 ms</p>	<p>1.1 light sensed warning (low excess gain) sensor test, disable emitter change of modulation frequency light-/dark operate off delay, 20 ms</p>
<p>250¹⁾</p>	<p>250¹⁾</p>	<p>250¹⁾</p>
<p>VALOX® (PBT) Acryl Lexan® (PC) IP67 -25...+70</p>	<p>VALOX® (PBT) Acryl Lexan® (PC) IP67 -25...+70</p>	<p>VALOX® (PBT) Acryl Lexan® (PC) IP67 -25...+70</p>
<p>LED LED</p>	<p>LED LED</p>	<p>LED LED</p>

AS-Interface® - Ultrasonic Sensors

- **Integrated AS-Interface®**
- **0.3... 6 m sensing range**
- **Three individually adjustable sensing ranges**
- **Alarm indication via bus in case of sensor failure**
- **Many programmable parameters**

Operating Principle

Ultrasonic sensors use sound waves to detect the presence of an object: the sensor emits an ultrasonic pulse which reflects back from any object. From the time it takes for this echo to return, the sensor determines the distance to the object.

Sensing Ranges

With ultrasonic sensors, distinct ranges can be set within which an object generates a switching signal. Objects outside these ranges may be detected but do not switch the output.

Ultrasonic Sensors With Integrated AS-Interface®

Ultrasonic sensors incorporating an AS-i chip have three sensing ranges. It is possible to program and adjust these sensing ranges with the ASI-PD01 programming device.

Data bit 0...2 indicate whether an object has entered one of the sensing ranges. Data bit 3 is utilized whenever the sensor is not working properly.

Programming

With the ASI-PD01 programming device, the following parameter adjustments can be made:

- end value of the three sensing ranges
- average value forming
- switching hysteresis

- Threaded metal barrel, M 30 x 1.5
- *euromast*® connectors

		<i>RU30-M30-ASIX3-</i> <i>H1140</i> <i>18 710 05</i>	<i>RU130-M30-ASIX3-</i> <i>H1140</i> <i>18 710 10</i>	<i>RU300-M3047-ASIX3-</i> <i>H1140</i> <i>18 710 15</i>	<i>RU600-M3065-ASIX3-</i> <i>H1140</i> <i>18 710 20</i>
Connection					
Electrical version		DC			
Dimensions		M 30 x 1,5 	M 30 x 1,5 	M 30 x 1,5 	
Wiring diagram					
Sensing range	[cm]	6...30	20... 130	40...300	60...600
Blind zone	[cm]	6	20	40	60
Standard target	[cm ²]	1 x 1	2 x 2	10 x 10	10 x 10
Adjustments		see page 26			
Number of sensing ranges		3			
Supply voltage U _B	[VDC]	26.9... 33.6		26.9...33.6	26.9...33.6
No-load current	[mA]	75			
AS-i profile					
Data bit 0		sensing range 1		sensing range 1	sensing range 1
Data bit 1		sensing range 2		sensing range 2	sensing range 2
Data bit 2		sensing range 3		sensing range 3	sensing range 3
Data bit 3		alarm		alarm	alarm
Parameter bits 0...3		see page 26			
Switching frequency	[Hz]	8	4	2	1
Switching hysteresis (programmable)	[cm]	1		2	6
Repeatability	[mm]	± 0.45	± 2	± 5	± 9
Temperature drift		± 1.5			
Material housing		anodized aluminium			
Material sensing face		Epoxy resin			
Material end cap		-			
Degree of protection (IEC 60529/EN 60529)		IP65			
Operation temperature	[° C]	-25...+70			
Torque	[Nm]	60			
Cable/clamping ability		<i>euromast</i> ®			
Switching status indication	LED	3 x yellow			

AS-Interface® - Accessories

Address Programming And Service Devices

For maintenance and system set-up, the AS-i programming device is required to carry out the initial station addressing. All active stations (slaves) must have an AS-i address (1...31) assigned before they can be installed. (Exception: If a station is being replaced by a new one having the address „0“, it is automatically allocated to the address of the destroyed station. In this case, the address allocation is carried out by the master).

Programming devices are available in two different versions to meet a wide variety of application requirements:

ASI-PD 02

This addressing device is used to enter the module specific address into the station. It provides only essential functions such as:

- read AS-i slave address
- write AS-i slave address
- AS-i specific function check

ASI-PD 01

This device serves for station addressing, but it is also used for the following functions:

- monitoring
- parameter programming
- system diagnosis
- maintenance

Addressing And Parameter Programming Via PC

A special software is available for some master stations (e. g. ASI-MM232) allowing address changes and parameter programming of AS-i substations via a PC. In that case the programming device is not required.

Power Supply Units

AS-i prescribes the use of a power supply with a built-in AS-i low pass filter to eliminate operation errors in the network. The AS-i power supply unit ASI- PS can provide a fully configured AS-i trunk with power. Use only ASI-PS from TURCK. Use of other power supplies can result in unreliable operation.

Cordsets And Interconnect Products

In case connections between the I/O stations and the AS-i cable are carried out in insulation penetration technology, the trapezoidal coded AS-i cable (see fig. 8) must be used to ensure correct polarity connections, proper seals, etc.

To meet the various application requirements, TURCK offers several cable qualities, e.g. the yellow AS-i cable with a rubber cable jacket has self-healing properties to seal cable perforations which inevitably occur with insulation penetration, but it is not especially resistant against environmental influences. The Polyurethane cable is uniquely resistant to chemicals and abrasion, but it does not have the self-healing characteristic.

The cable colour coding is also important:

- yellow: AS-i bus cable
- black: AS-i supply cable 24 VDC
- red: AS-i supply cable 230 VAC

Alongside the AS-i standard modules, there are modules with *eurofast*® options available. These are utilized where flat cables are not recommended, or if screw terminals are too cumbersome (see section „Stations“).

For simple and low cost connections between the stations, field devices and controllers, TURCK has a broad selection of interconnection products, including junctions and moulded bus tees, as well as simple cordsets.

TURCK also has a wide variety of standard M12 screw connectors in addition to the larger bus cables and connectors.

Pre-assembled Cables In Different Lengths, Materials And Versions

- Moulded cordsets for sensors:
 - straight female/straight male connector;
 - straight female/right-angle male connector;
 - right angle male/straight male connector;
 - right angle female/right angle male connector
- Moulded cordsets for actuators:
 - valve plug with straight connector
 - valve plug with right angle connector

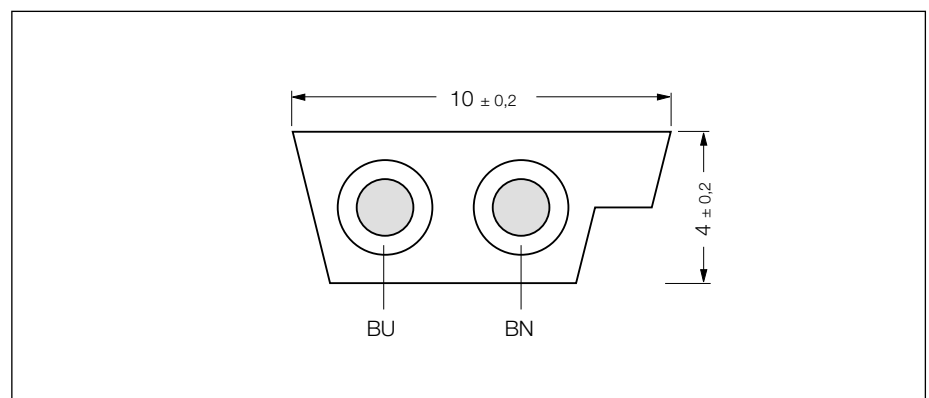

Fig. 8 Standard AS-i flat cable



ASI-BM 11 PG 68 216 02 <i>Pg screw connection</i>	ASI-BM 21 68 216 01 <i>insulation penetration</i>	ASI-BM-1000 - <i>insulation penetration</i>	FKM4.22-2FSM4.22 66 025 74	ASI-BM-0001 68 216 06	ASI-BM-0002 68 216 07	ASI-BMD 68 216 04
base module	base module	base module	tee piece	mounting plate for compact module	base module for EEMS	cover for base module
-	-	-	-	-	-	-
-	-	-	-	-	-	-
AS-i cable	AS-i cable	AS-i cable	round cable M12	-	AS-i cable	-
-	-	-	-	-	-	-
-	-	-	-	-	-	-
-	-	-	-	-	-	-
-	-	-	-	-	-	-
modular	modular	modular	modular	modular	modular	modular
-	-	-	-	-	-	-
-	-	-	-	-	-	-
IP67	IP67	IP67	IP67	IP67	IP67	IP67
-25... +75 °C	-25... +75 °C	-25... +75 °C	-25... +75 °C	-25... +75 °C	-25... +75 °C	-25... +75 °C
-	-	-	-	-	-	-
-	-	-	-	-	-	-
-	-	-	-	-	-	-
-	-	-	-	-	-	-

Register of components

A	Page
ASI-BM-0001	31
ASI-BM-0002	31
ASI-BM 11 PG	31
ASI-BM 21	31
ASI-BM 1000	31
ASI-BMD	31
ASI-C	30
ASI-CB	30
ASI-CGG	30
ASI-CPG	30
ASI-CR	30
ASI-CP 2430	5
ASI-CP 2433	5
ASi-DPG-0001	5
ASI-DEV-0001	6
ASI-GATEWAY	5
ASI-IM 41	11
ASI-IM 4-1000	11
ASI-IOM 22-1000	13
ASI-IOM 22-0003	13
ASI-IOM 221	12
ASI-IOM 44-1000	12
ASI-IOM 44-1001	13
ASI-IOM 441-0001	12
ASI-IOM 441-0002	12
ASI-MM 232	6
ASI-MM 232/C	7
ASI-MM 485	6
ASI-MM 485/C	7
ASI-MOD-0001	6
ASI-MOD-0001/C	7
ASI-OM 4-1000	15
ASI-OM 41	15
ASI-PD 01	29
ASI-PD 02	29
ASI-PM 11	13
ASI-PM 41	13
ASI-PS	29
ASI-PS-11-0001	29
ASI-PS-11-0002	29
ASI-T	30

B	Page
Bi5U-M18-ASIX-H1140	18
Bi10U-M30-ASIX-H1140	18
Bi15U-CK40-ASIX2-H1140	19
Bi15U-CP40-ASIX2	19

F	Page
FKM4.22-2FSM4.22	31



Register of components

N	Page
Ni12U-M18-ASIX-H1140	18
Ni20U-M30-ASIX-H1140	18
Ni25U-CK40-ASIX2-H1140	19
Ni75U-CP80-ASIX2	19

Q	Page
Q40-X21-FF200-Q	22
Q40-X21-FF400-Q	23
Q40-X21-LP-Q	22
Q45-XAS1-CV-Q	25
Q45-XAS1-CV4-Q	25
Q45-XAS1-D-Q	24
Q45-XAS1-DL-Q	24
Q45-XAS1-E-Q	25
Q45-XAS1-F-Q	25
Q45-XAS1-FP-Q	25
Q45-XAS1-LP-Q	24
Q45-XAS1-LV-Q	24
Q45-XAS1-R-Q	25

R	Page
RU30-M30-ASIX3-H1140	27
RU130-M30-ASIX3-H1140	27
RU300-M3047-ASIX3-H1140	27
RU600-M3065-ASIX3-H1140	27

S	Page
S30-X21-FF200-Q	22
S30-X21-FF400-Q	23
S30-X21-LP-Q	22

T	Page
T30-X21-FF200-Q	22
T30-X21-FF400-Q	23
T30-X21-LP-Q	22

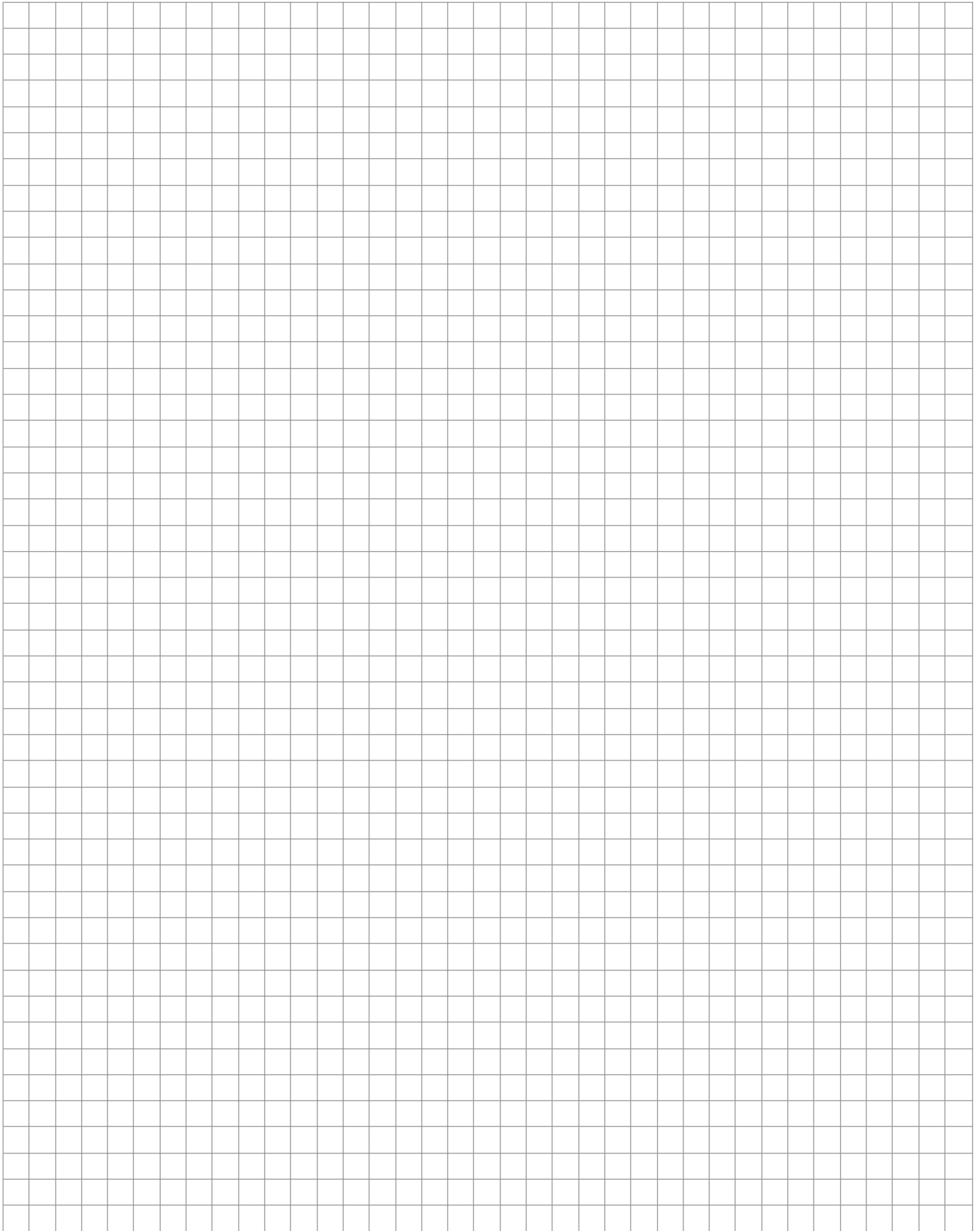

Bitte senden Sie mir Unterlagen:

Please send me more information:

Sensortechnik

- Induktive Sensoren
- uprox*[®] induktive Sensoren
- Kapazitive Sensoren
- Magnetfeldsensoren
- Opto-Sensoren
- Geräte für den Personenschutz
- Ultraschall-Sensoren
- Strömungswächter
- Druckwächter
- Temperaturwächter
- Steckverbinder
- CD-ROM Sensortechnik

Sensors

- inductive sensors
- uprox*[®] inductive sensors
- capacitive sensors
- magnetic-field sensors
- photoelectric sensors
- machine safety equipment
- ultrasonic sensors
- flow controls
- pressure controls
- temperature controls
- connectors
- CD-ROM Sensors

Interfacetechnik

- Interfacetechnik im Aufbau-gehäuse
 - Bauform *multimodul*
 - Bauform *multisafe*[®]
- Allgemeine Informationen
- Interfacetechnik auf 19"-Karte
 - Bauform *multicart*[®]
- Miniaturrelais, Industrierelais, Zeitwürfel, Sockel
- Zeit- und Überwachungsrelais
- Ex-Schutz - Grundlagen für die Praxis (Übersichtsposter)
- CD-ROM Interfacetechnik

Interface technology

- devices in modular housings
 - *multimodul* style
 - *multisafe*[®] style
- general information
- devices on 19" card
 - *multicart*[®] style
- miniature relays, industrial relays, time cubes, sockets
- programmable relays and timers
- explosion protection - basics for practical application (overview poster)
- CD-ROM Interface technology

Feldbustechnik

- busstop*[®]-Feldbuskomponenten
- Bussystem *sensoplex*[®] 2
- Bussystem *sensoplex*[®] 2 Ex
- Bussystem *sensoplex*[®] MC
- Bussystem AS-Interface[®]
- Bussystem DeviceNet[™]
- Bussystem FOUNDATION[™] fieldbus
- Bussystem PROFIBUS-DP
- Bussystem PROFIBUS-PA
- Bussystem *piconet*[®]
- Bussystem *excom*[®]
-

Fieldbus technology

- busstop*[®] fieldbus components
- bus system *sensoplex*[®] 2
- bus system *sensoplex*[®] 2 Ex
- bus system *sensoplex*[®] MC
- bus system AS-Interface[®]
- bus system DeviceNet[™]
- bus system FOUNDATION[™] fieldbus
- bus system PROFIBUS-DP
- bus system PROFIBUS-PA
- bus system *piconet*[®]
- bus system *excom*[®]
-



FAX-ANTWORT/FAX REPLY

Absender/Sender: _____

Name: _____

Firma/Company: _____

Abt./Position: _____

Adresse/Address: _____

Tel./Phone: _____ Fax: _____

E-Mail: _____

TURCK

High Technology Sensors
and Automation Controls

