

# HOUSING STYLES

Rectangular, compact, static output		
Sensor style	Ring Ø	Min. target size (steel ball)
Q14	6 mm	2 mm
Q14	10 mm	2 mm
Q14/W30S	15 mm	3 mm
Q14/W30S	20 mm	4 mm
Q20	30 mm	6 mm
Q80	50 mm	8 mm
Q80	65 mm	10 mm

3-wire DC, pnp or npn, 10... 30 VDC, static output, 100 ms min. pulse length, cable or connector, vertical or horizontal alignment to tube

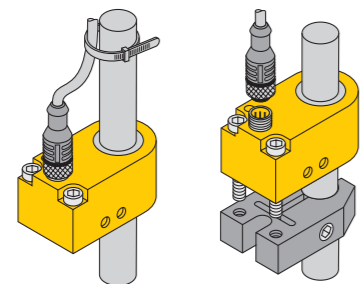
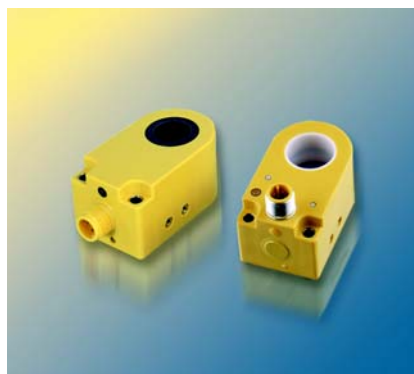
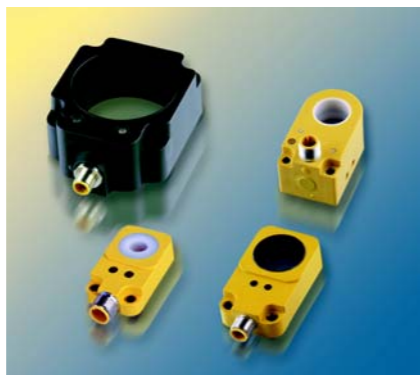

With type W30S, the cable can be mounted directly to the tube! Reduced space requirements, no cable bothersome loops.

Mounting accessories for W30 and W30S ring sensor types for direct mounting on the tube available.

Rectangular, dynamic output, highly sensitive		
Sensor style	Ring Ø	Min. target size (steel ball)
W30	6 mm	0.6 mm
W30	10 mm	1 mm
W30	15 mm	1.5 mm
W30	20 mm	2 mm
W30	30 mm	3 mm

3-wire DC, pnp or npn, 10 ... 30 VDC, dynamic output, 100 ms pulse duration, cable or connector devices

Rectangular, modular dynamic output, highly sensitive		
Sensor style	Ring Ø	Min. target size (steel wire)
S32	10 mm	0.2 mm
S32	20 mm	0.4 mm
S32	40 mm	1.0 mm
S32	65 mm	2.0 mm

3-wire DC, pnp or npn, 10 ... 55 VDC, static output, 100 ms min. pulse duration, terminal chamber or connector, sensitivity adjustment

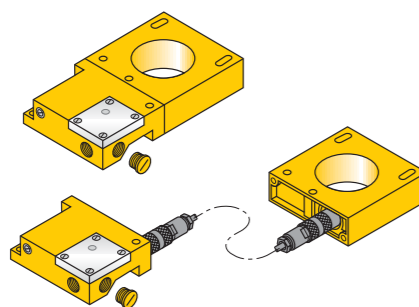

Ring sensor series S32 includes self-contained compact versions and sensors with a separate amplifier



Rectangular, compact, analogue output				
Sensor style	Measuring range mm Ø			
	Ring Ø	St37	VA	NF metals
Q14	20 mm	1 ... 10	2 .. 17	4 ... 19

15 ... 30 VDC supply voltage, 0 ... 10 V output, cable or connector devices

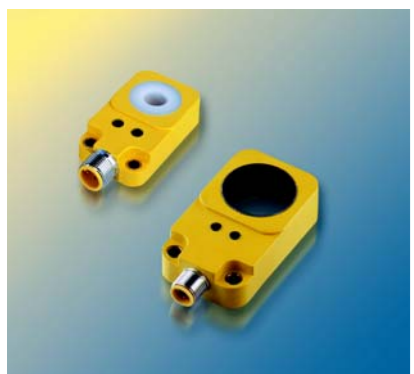

# TURCK

Industrial Automation

## INDUCTIVE RING SENSORS

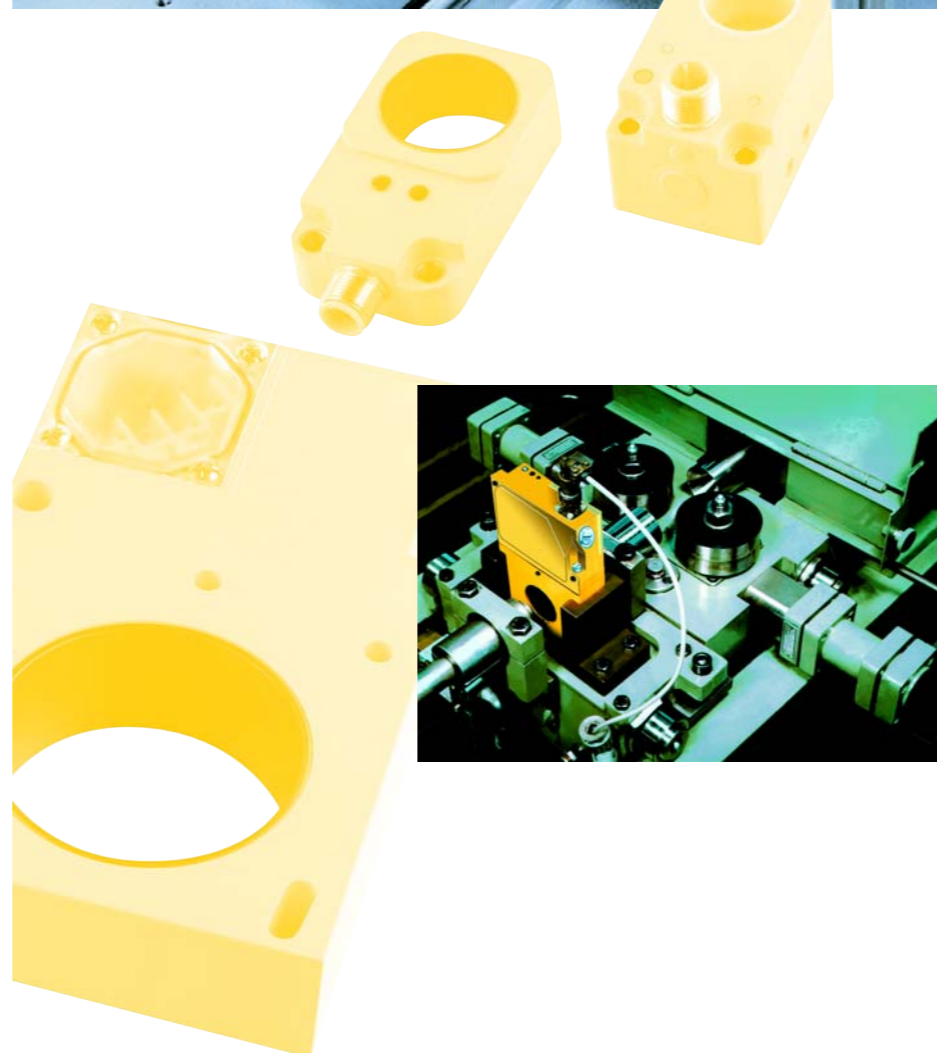
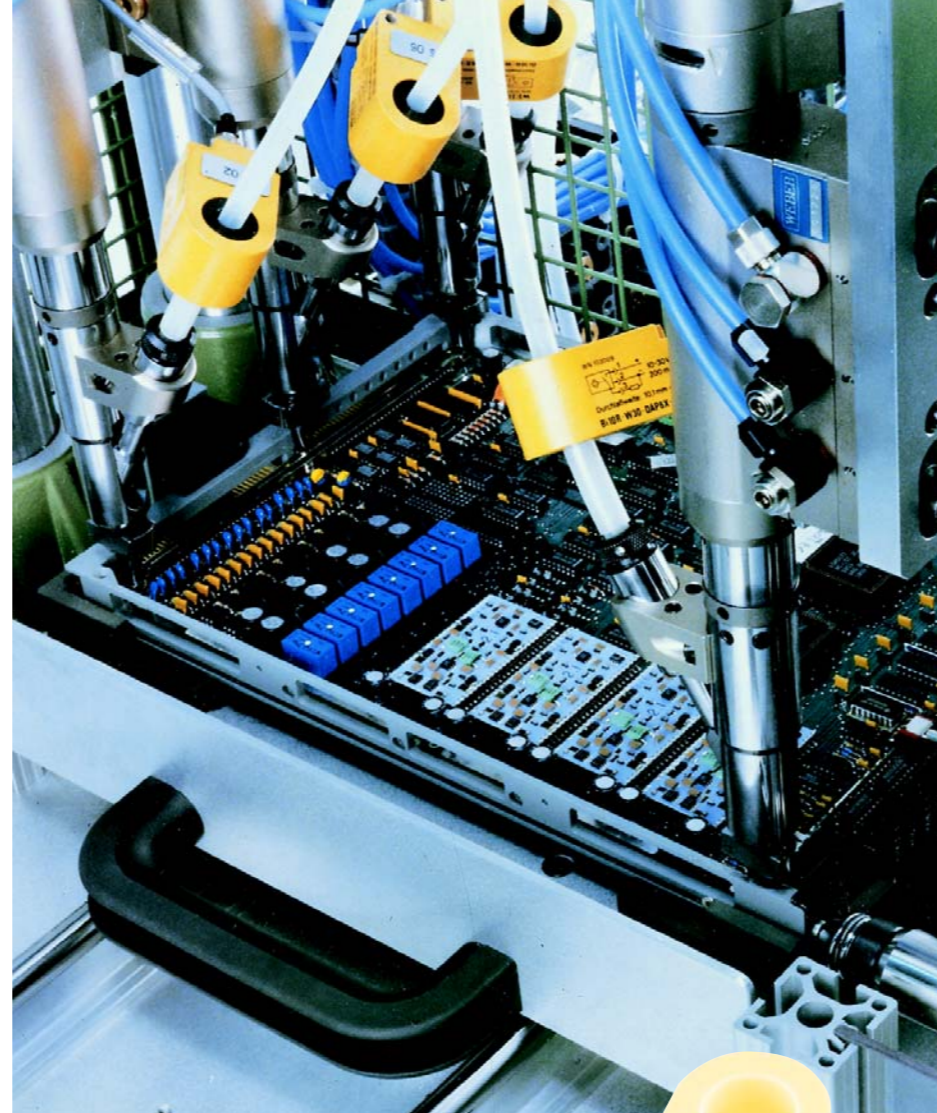

Bitte senden Sie mir Unterlagen:

### Sensortechnik

- Induktive Sensoren
- Induktive Sensoren für Schwenkantriebe
- uprox® induktive Sensoren
- Kapazitive Sensoren
- Magnetfeldsensoren
- Opto-Sensoren
- Geräte für den Personenschutz
- Ultraschall-Sensoren
- levelprox-Füllstandssensoren
- Strömungswächter
- Druckwächter
- Temperaturwächter
- Identifikations-Systeme
- Linearweg-Sensoren
- Drehweg-Sensoren
- Steckverbinder
- CD-ROM Sensortechnik

### Interfacetechnik

- Interfacetechnik im Aufbauehäuse für Hutschienen- (DIN50022), Platten- oder Bodenmontage
- Interfacetechnik auf 19"-Karte für Baugruppenträger (DIN 41494)
- Miniaturrelais, Industrirelais, Zeitwürfel, Sockel
- Zeit- und Überwachungsrelais
- Ex-Schutz – Grundlagen für die Praxis (Übersichtsposter)
- CD-ROM Interfacetechnik

### Feldbustechnik

- busstop®-Feldbuskomponenten
- Bussystem sensoplex®2
- Bussystem sensoplex®2 Ex
- Bussystem sensoplex®MC
- Bussystem AS-Interface®
- Bussystem DeviceNet™
- Ethernet Netzwerkkomponenten
- BL20 I/O-Busklemmensystem
- Bussystem FOUNDATION™ fieldbus
- Bussystem PROFIBUS-DP
- Bussystem PROFIBUS-PA
- Bussystem piconet®
- Remote I/O excorm®
- .....

Please send me more information:

### Sensors

- inductive sensors
- inductive sensors for rotary actuators
- uprox® inductive sensors
- capacitive sensors
- magnetic-field sensors
- photoelectric sensors
- machine safety equipment
- ultrasonic sensors
- levelprox level sensors
- flow controls
- pressure controls
- temperature controls
- identification systems
- linear position sensors
- rotary position sensors
- connectors
- CD-ROM Sensors

### Interface technology

- devices in modular housings for top-hat rail (DIN50022) or panel mounting
- devices on 19" card for DIN-rail mounting (DIN 41494)
- miniature relays, industrial relays, time cubes, sockets
- programmable relays and timers
- explosion protection – basics for practical application (overview poster)
- CD-ROM Interface technology

### Fieldbus technology

- busstop® fieldbus components
- bus system sensoplex®2
- bus system sensoplex®2 Ex
- bus system sensoplex®MC
- bus system AS-Interface®
- bus system DeviceNet™
- Ethernet network components
- BL20 I/O bus terminal system
- bus system FOUNDATION™ fieldbus
- bus system PROFIBUS-DP
- bus system PROFIBUS-PA
- bus system piconet®
- Remote I/O excorm®
- .....

## FAX-ANTWORT/FAX REPLY

Absender/Sender: \_\_\_\_\_

Name: \_\_\_\_\_

Firma/Company: \_\_\_\_\_

Abt./Position: \_\_\_\_\_

Adresse/Address: \_\_\_\_\_

Tel./Phone: \_\_\_\_\_

Fax: \_\_\_\_\_

E-Mail: \_\_\_\_\_

# TURCK

Industrial Automation

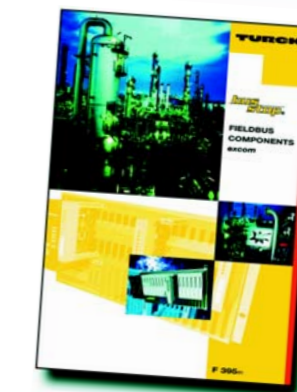

**Hans Turck GmbH & Co. KG**  
 D-45466 Mülheim an der Ruhr  
 Phone (+49) (2 08) 49 52-0  
 Fax (+49) (2 08) 49 52-264  
 E-Mail turckmh@mail.turck-globe.de  
 Internet www.turck.com



D101369 0203

## TURCK RING SENSORS: RELIABLE DETECTION OF MINIATURE COMPONENTS

### Ring sensors

Inductive ring sensors feature a rotation-symmetric coil array. This special structure induces a concentrated magnetic field inside the coil.



Due to the symmetric coil array of inductive ring sensors, even the most minute metal parts can be detected safely and reliably, independently of their position within the ring. These sensors are particularly suited for detection of parts of varying position that are flexibly guided. The product range comprises versions with static and dynamic switching outputs as well as types with analogue voltage output.

Ring sensors are capable of conveniently solving many applications, which are difficult or even impossible to solve with standard sensors, e.g. reliable monitoring of small parts assembly operations such as feeder tubes in

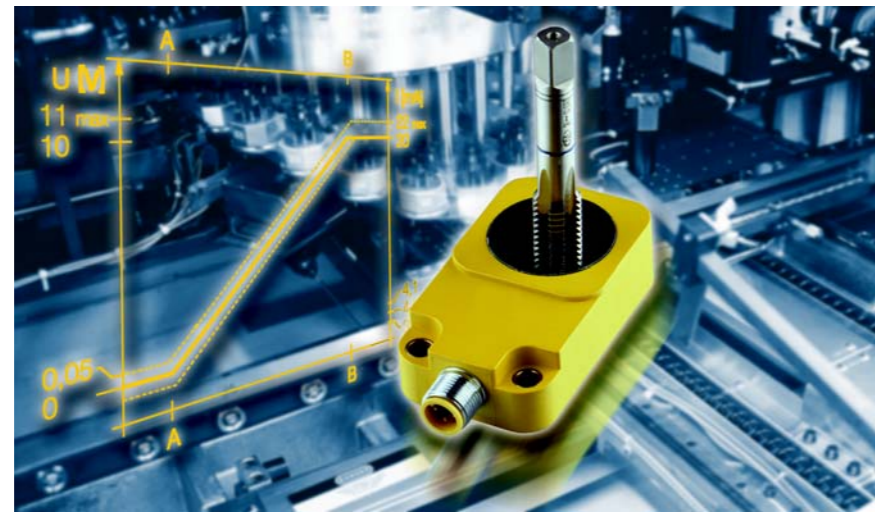

automatic screwing or riveting machines or other automated assembly systems. Wire break or tear control in wire drawing processes is easily and reliably accomplished by ring sensors.

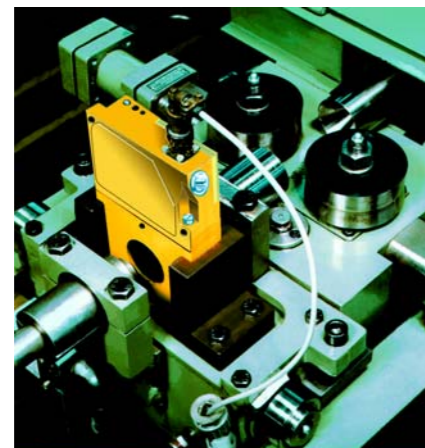

### New: ring sensors with analogue output

Analogue ring sensors are not only designed to identify wires and screws of variable size and thickness, but also to differentiate identically sized parts on the basis of their material. Every material generates a specific voltage signal which can then be evaluated by the controller. Displacement measurements are also simply accomplished by means of a cone-shaped target.

### Convincingly versatile

- Ring diameters of 6 to 65 mm
- Static, dynamic and analogue versions
- With integrated amplifier or a separable combination of probe and amplifier
- Highly sensitive, adjustable up to a minimum target diameter of 0.6 mm/minimum wire cross section of 0.2 mm
- Compact housing styles
- Excellent EMC

## RING SENSORS WITH SWITCHING OUTPUT

### Static sensors

Static ring sensors generate a constant pulse if a metal part is within the ring. This sensor is typically suited for a wide spectrum of applications.

The static performance allows detection of jamming parts in automatic assembly systems.

### Dynamic sensors

Dynamic sensors respond sensitively and create merely a short pulse upon actuation (TURCK ring sensors: 100 ms). Compared to static sensors, they are capable of detecting parts that are up to 8 times smaller.

### Application possibilities of binary ring sensors

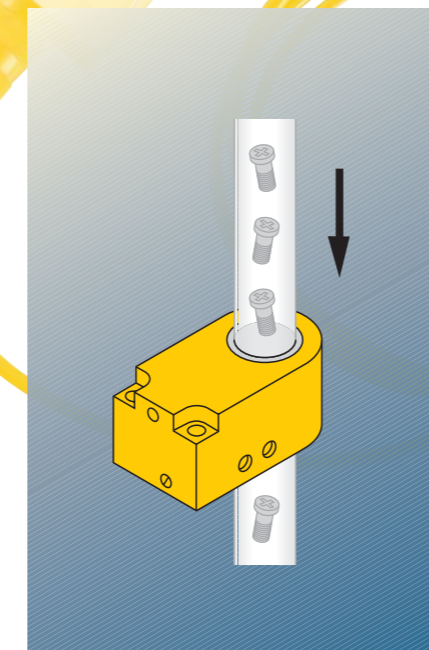

#### Ejection control

In punching machinery or, for example, in recycling systems that produce plastic granulate material, ejection control is needed. The sensor can be used either to detect small metal parts, which contaminate the material, or to create a counting pulse. Both static or dynamic ring sensors can be used for this application, depending on the user's space and sensitivity requirements.

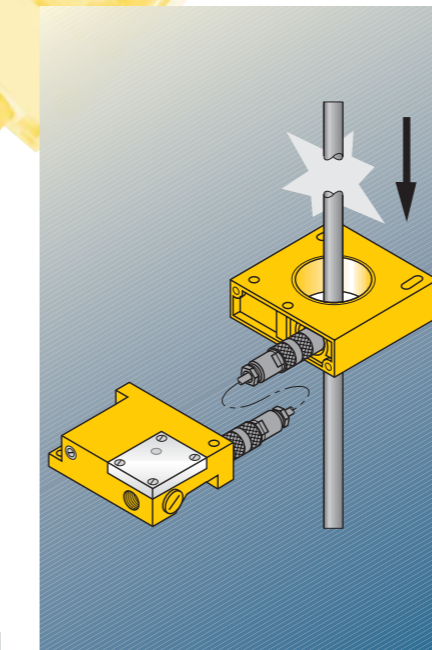

#### Wire break monitoring

Wire break monitoring tasks can only be accomplished with static ring sensors. The sensor series S32, designed especially for this purpose, features a modular structure, thus increasing the mechanical stability and ensuring exchangeability. In the event of a sensor failure or defect merely the ring probe and not the amplifier has to be replaced. Separate mounting of the amplifier is also possible, e.g. to avoid temperature problems.

#### Parts feeding control

In automated assembly applications ring sensors are used, for example, for detection of metal parts in the feeder tubes of riveting and screwing machinery; parts jam detection is also possible. If the targets are very small or are ejected at high speed, dynamic rings sensors are the best choice. They are up to 8 times more sensitive than static sensors. However, dynamic sensors are not capable of detecting a parts jam.

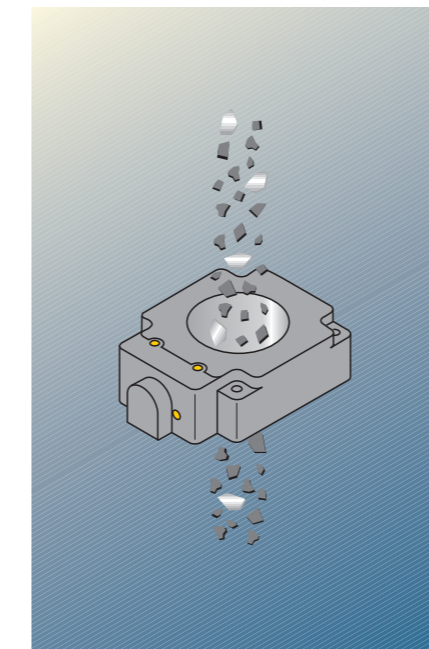

## RING SENSORS WITH ANALOGUE OUTPUT

### Identification of small parts and position control

The analogue ring sensor is a new development in the range of ring sensors. The combination of high precision analogue sensing technology with the symmetric coil arrangement of a ring sensor yields distinct advantages for many applications. Due to the

concentrated magnetic field inside the ring sensor, the attenuation variable is hardly affected by the exact position of the target in the ring. Consequently, a stable and constant output signal is generated even if the target position in the ring fluctuates. This technology makes it

possible to profile small parts (screws, rivets or the like), to distinguish between different tools or to implement an affordable means of position control.

### Application possibilities of analogue ring sensors

#### Identification of small parts

When falling through the ring, screws, rivets or other small parts, e.g. screws of different size, generate a characteristic output signal, so that the target can be distinguished easily. Due to the concentrated magnetic field, even flexibly guided parts do not create problems.

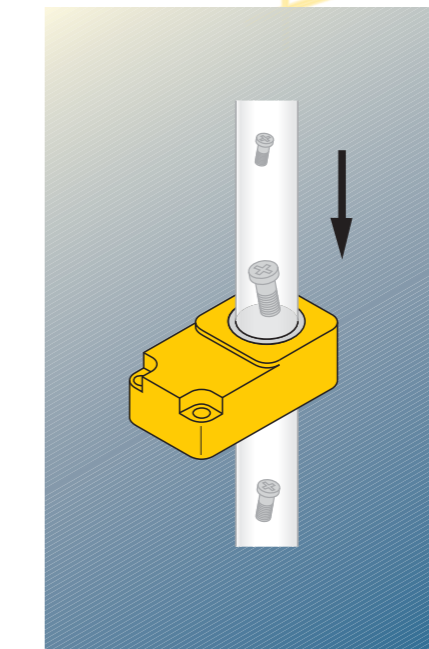

#### Thickness measurement, parts detection

Analogue ring sensors are capable of distinguishing and identifying parts of different shape and size. A tooling change monitoring function is also implemented easily.

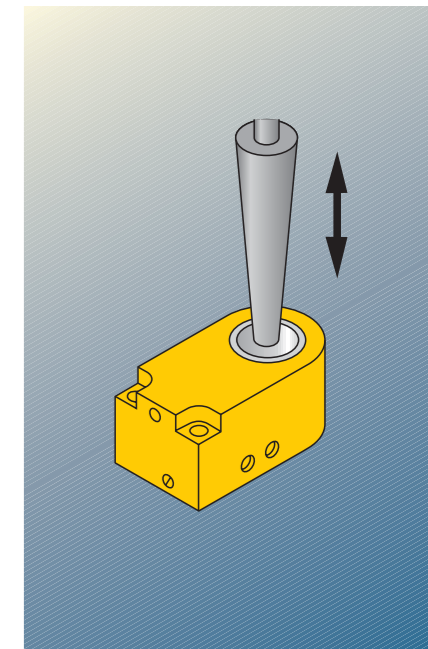

#### Position control

Position control can be easily accomplished by means of a cone-shaped target. Measuring ranges can be adapted to specific sensing needs by using targets with an appropriate cone length. These sensors enable precise and simple position detection, even if the targets feature a slight offset.

